

Patternbook

2026 Big Dream Summer Slide Norway Open

#4	AQHA	412000	Youth	Showmanship
#5	APHA	YSH1	Youth	
#9	AQHA	212000	Amateur	
#10	APHA	ASH1	Amateur	

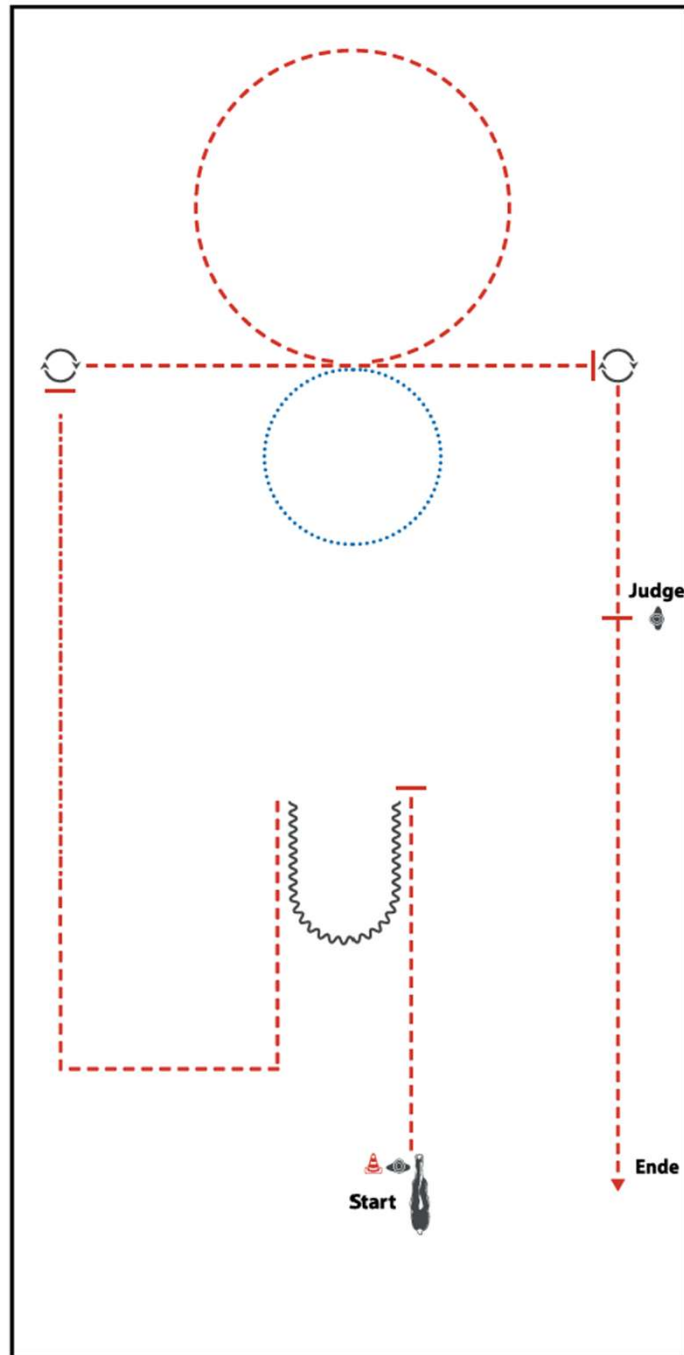

BE READY AT MARKER

- 1) TROT, STOP
- 2) BACK UP
- 3) TROT CORNERS, EXTENDED TROT
- 4) STOP, TURN 450°
- 5) TROT, WALK SMALL CIRCLE TO THE RIGHT, TROT SMALL CIRCLE TO THE LEFT
- 6) STOP, TURN 450°
- 7) TROT, STOP WITH THE HORSES HIP ALIGNED WITH THE JUDGE
- 8) SET UP
- 9) INSPECTION
- 10) TROT OUT

NORWEGIAN
QUARTER
HORSE
ASSOCIATION



Big Dream
ARENA

#80	NSBA	300601	Nonpro		Showmanship
#82	AQHA	112004	Nonpro	L1	

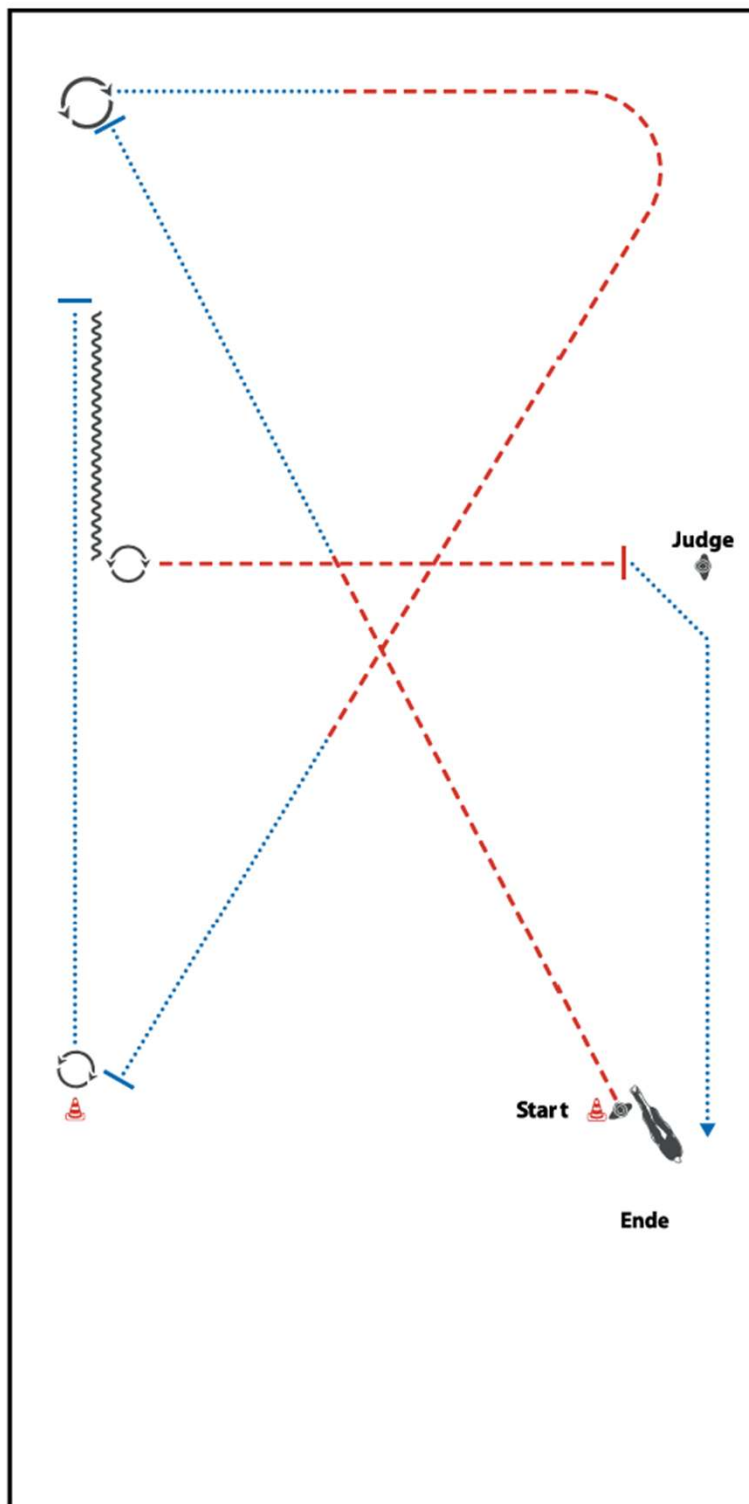

BE READY AT MARKER

- 1) TROT, WALK, STOP
- 2) TURN 495°
- 3) WALK, TROT, WALK, STOP
- 4) TURN 135°
- 5) WALK, STOP, BACK UP
- 6) TURN 450°
- 7) TROT, STOP
- 8) SET UP
- 9) INSPECTION
- 10) WALK OUT

NORWEGIAN
 QUARTER
 HORSE
 ASSOCIATION



#120 Allbreed	HSO	Open	Hunt Seat Equitation
#121 AQHA	252002	Amateur L1	
#122 APHA	NHS1	Amateur Novice	
#123 NSBA	360601	Nonpro	

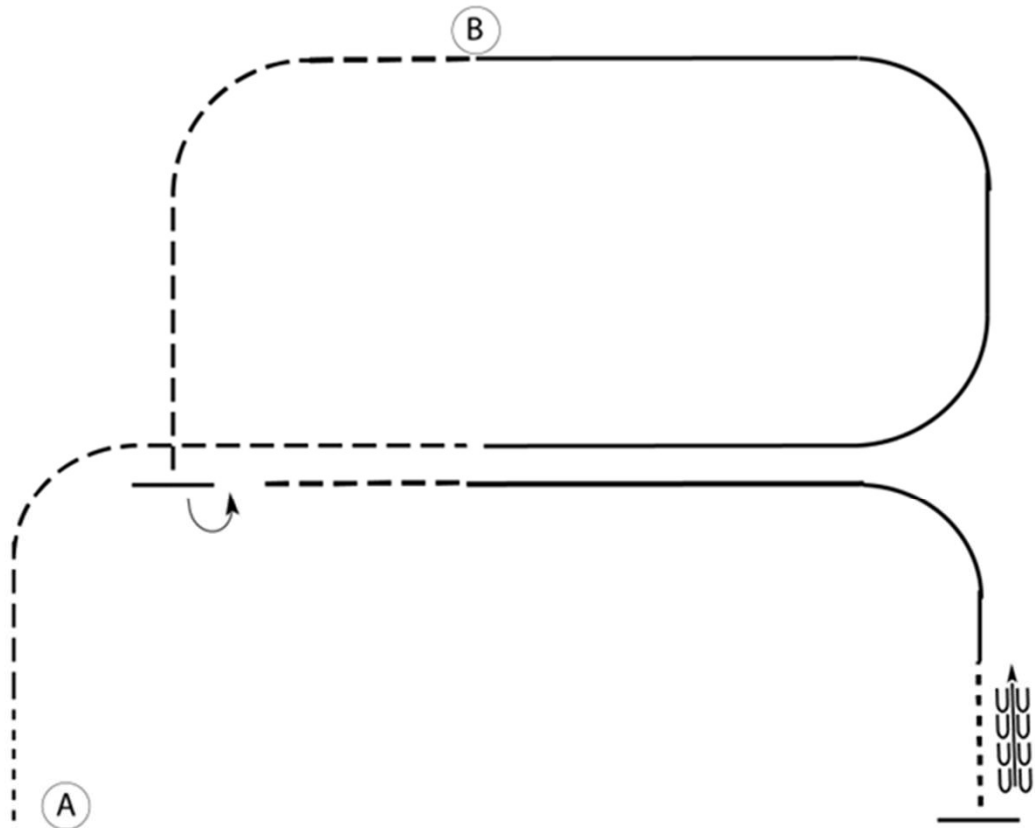

Be ready at A.

1. Forward walk for approximately 2 strides.
2. Trot on the left diagonal to center of pattern.
3. Canter on the left lead to B.
4. Trot on the right diagonal until halfway to A.
5. Stop and perform a 90 degree turn on the forehand to the left to change direction.
6. Sitting trot for 2-3 strides.
7. Canter on the right lead around corner.
8. Forward walk until even with A.
9. Stop and back.

Pattern is complete.

Walk	-----
Trot	- - - - -
Extended Trot	-----
Canter	—————
Leg Yield	
Lead Change	↗ ↘
Back	←←←←←
Marker	Ⓚ
Sidepass	←←←←←
Hand Gallop	—————

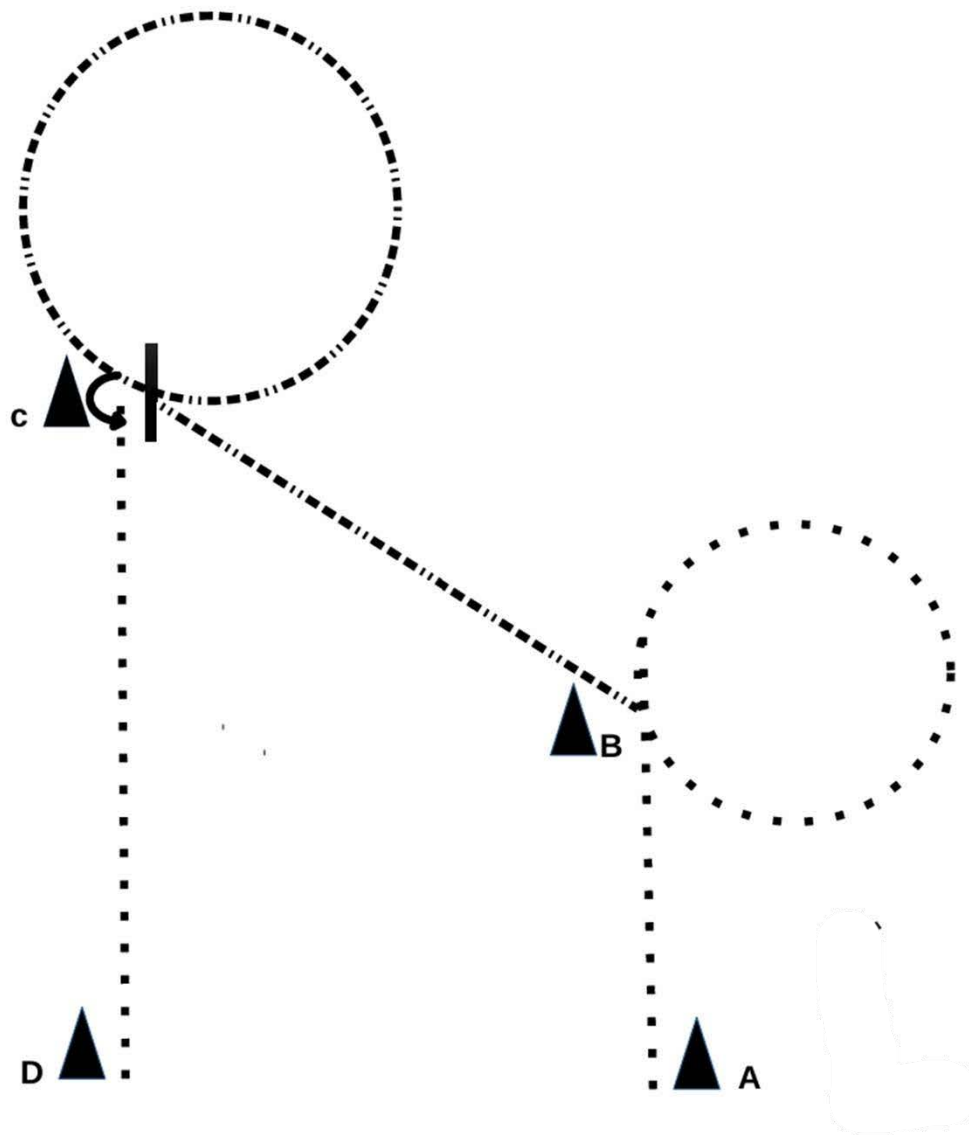

1. WALK FROM A TO B
2. WALK CIRCLE AT B
3. POSTING TROT EITHER DIAGONAL FROM B TO C
4. SITTING TROT CIRCLE AT C
5. STOP FRONTAL AT C
6. FOREHAND TURN AT C TO THE LEFT
7. WALK FROM C TO D

#133 Allbreed	IHTO	Open	Trail in hand
#134 NSBA	530380	Open 2%3 yrold	In-hand Trail
#135 AQHA	138300	Open 2&3 yrold	Trail in hand
#136 APHA	IHT2	Open 2yrold	
#137 APHA	IHT4	Open 3yrold	

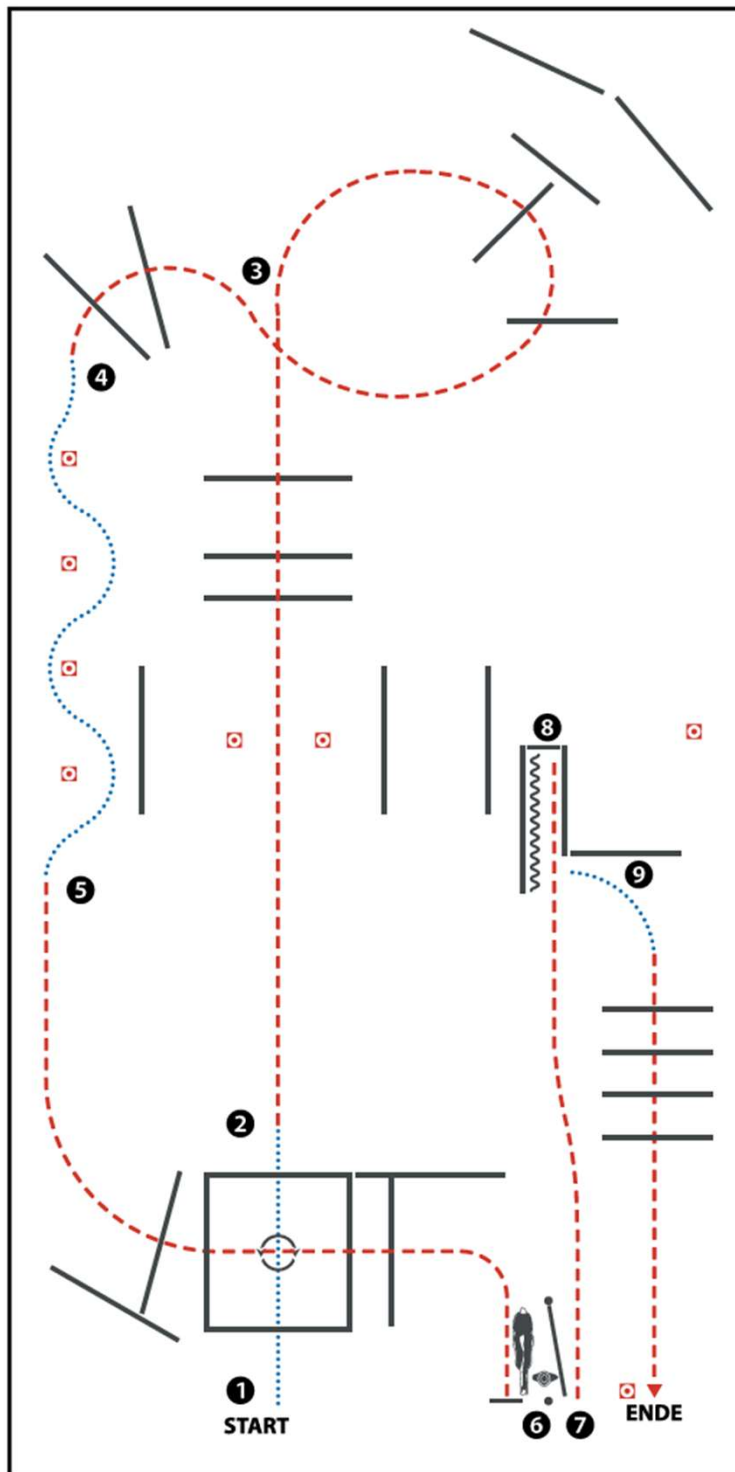

- 1) WALK INTO BOX, 360° TURN RIGHT WALK OUT
- 2) JOG OVER
- 3) JOG OVER
- 4) WALK SERPENTINE
- 5) JOG OVER
- 6) GATE LH
- 7) JOG INTO CHUTE
- 8) BACK UP, TURN RIGHT
- 9) WALK, JOG OVER

NORWEGIAN
QUARTER
HORSE
ASSOCIATION



Big Dream
ARENA

#138	AQHA	138004	Open L1	Trail
#139	APHA	GTR	Open Green	
#142	AQHA	238000	Amateur L1	
#143	APHA	NT1	Amateur Novice	

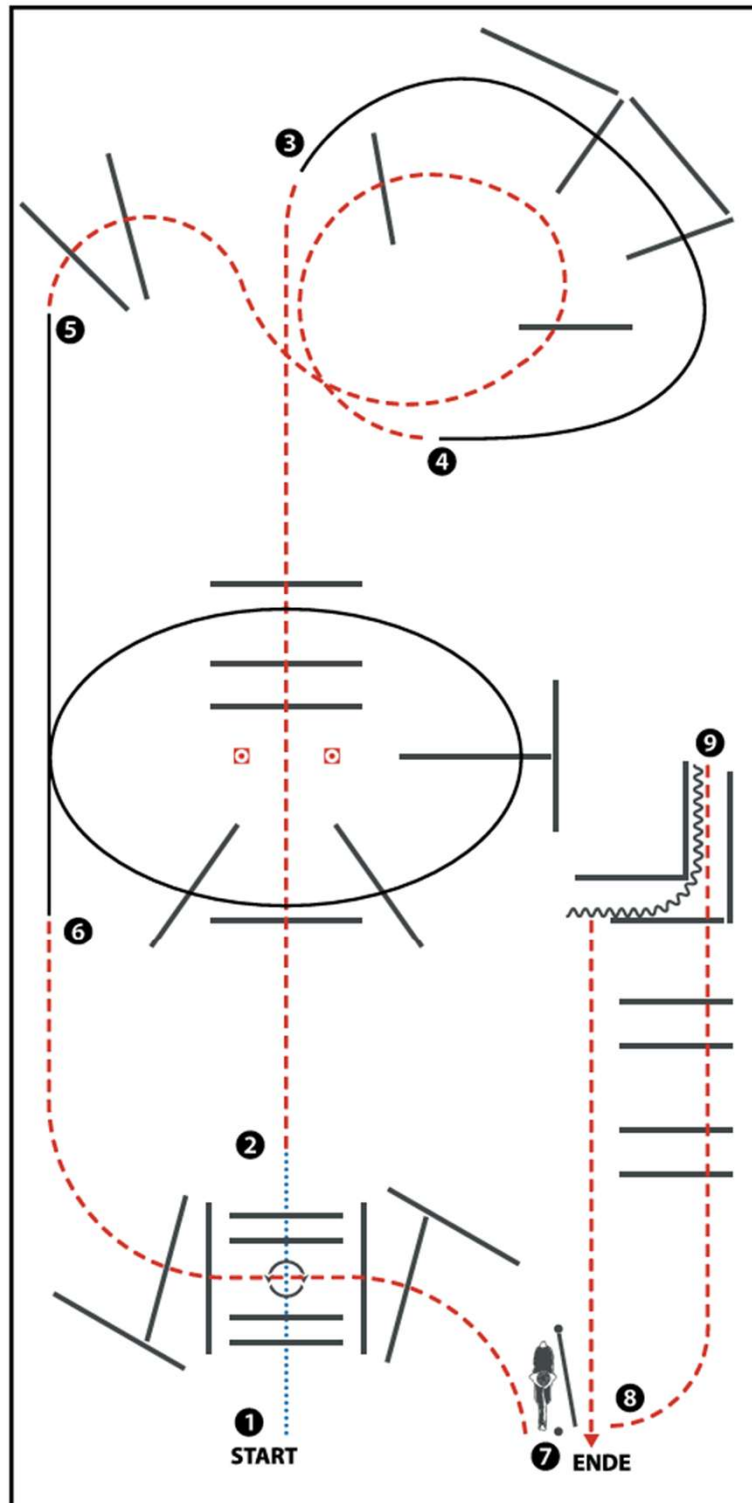

(Erhöhungen optional)

- 1) WALK OVER INTO BOX,
360° TURN (LEFT OR RIGHT), WALK OUT
- 2) JOG OVER
- 3) LOPE OVER (RL)
- 4) JOG OVER
- 5) LOPE OVER (LL)
- 6) JOG OVER
- 7) GATE LH
- 8) JOG OVER POLES AND INTO CHUTE
- 9) BACK UP, 90° TURN RIGHT, JOG OUT

NORWEGIAN
QUARTER
HORSE
ASSOCIATION



Big Dream
ARENA

#140
#141
#144

AQHA
APHA
NSBA

438000
YT1
330601

Youth
Youth
Nonpro

Trail

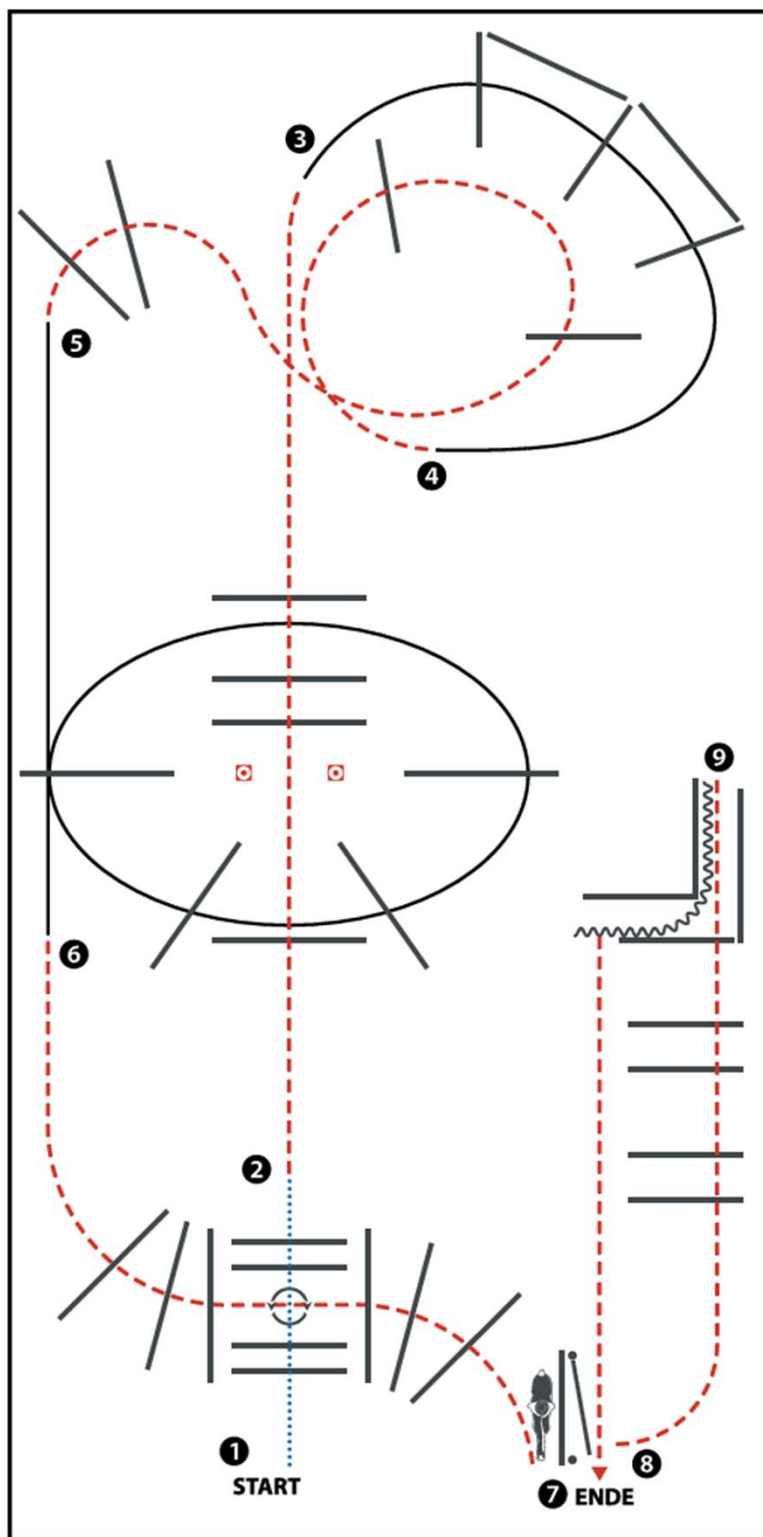

(Erhöhungen optional)

- 1) WALK OVER INTO BOX, 360° TURN (LEFT OR RIGHT), WALK OUT
- 2) JOG OVER
- 3) LOPE OVER (RL)
- 4) JOG OVER
- 5) LOPE OVER (LL)
- 6) JOG OVER
- 7) GATE LH
- 8) JOG OVER POLES AND INTO CHUTE
- 9) BACK UP, 90° TURN RIGHT, JOG OUT

NORWEGIAN
QUARTER
HORSE
ASSOCIATION



Big Dream
ARENA

#151	AQHA	238000	Amateur
#152	APHA	AT1	Amateur
#153	Allbreed	TRLO	Open
#159	Allbreed	TRY	Youth

Trail

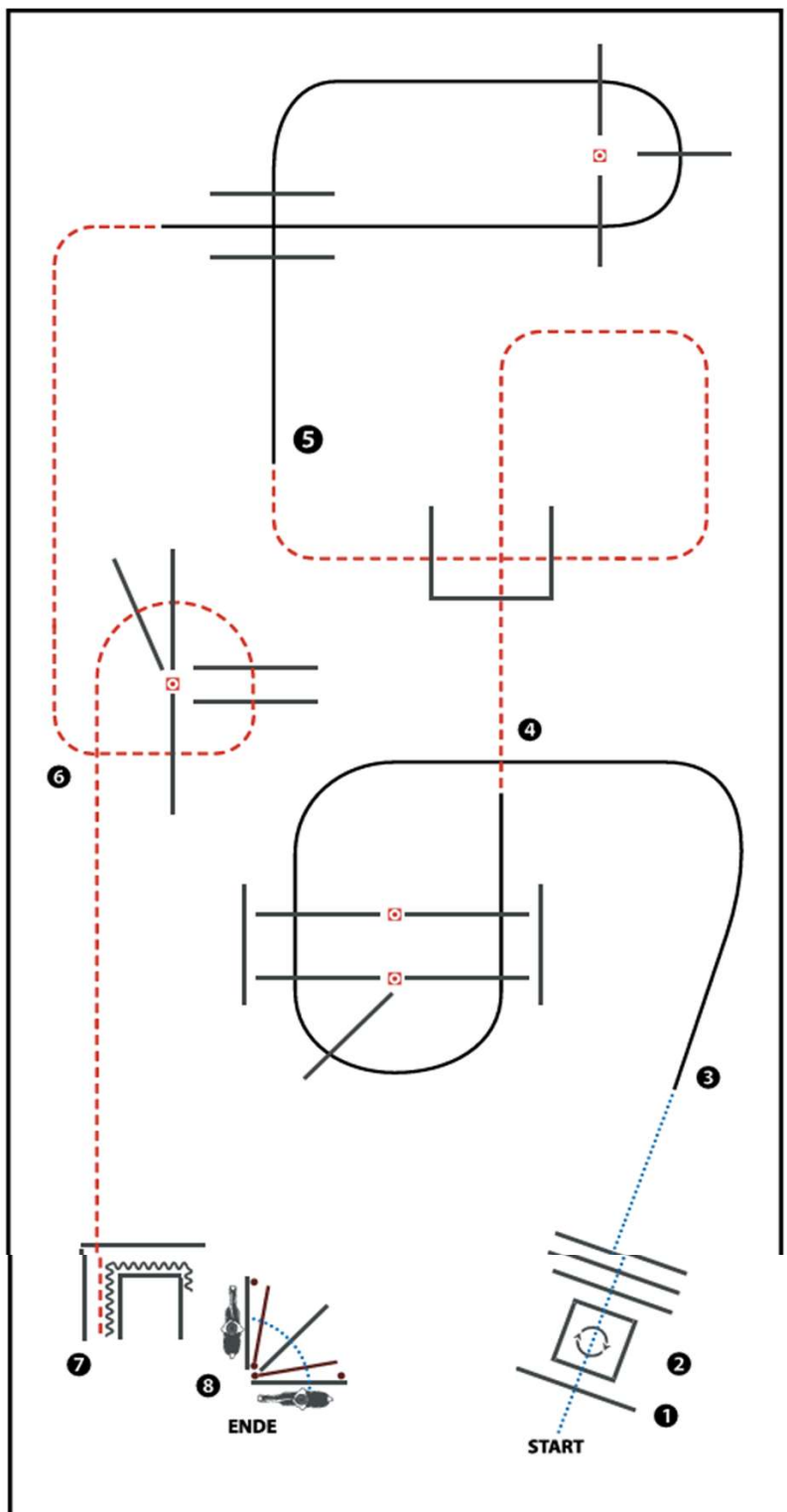

(Erhöhungen optional)

- 1) WALK OVER, INTO BOX,
TURN 360° EITHER WAY (LEFT OR RIGHT)
- 2) WALK OUT, WALK OVER
- 3) LOPE OVER (LL)
- 4) JOG OVER
- 5) LOPE OVER (RL)
- 6) JOG OVER
- 7) JOG IN, BACK UP
- 8) GATE RIGHT HAND OPEN, WALK OVER, CLOSE GATE

NORWEGIAN
QUARTER
HORSE
ASSOCIATION



Big Dream
ARENA

#154
#155

AQHA
APHA

138100
TRL2

Open jr
Open jr

Trail

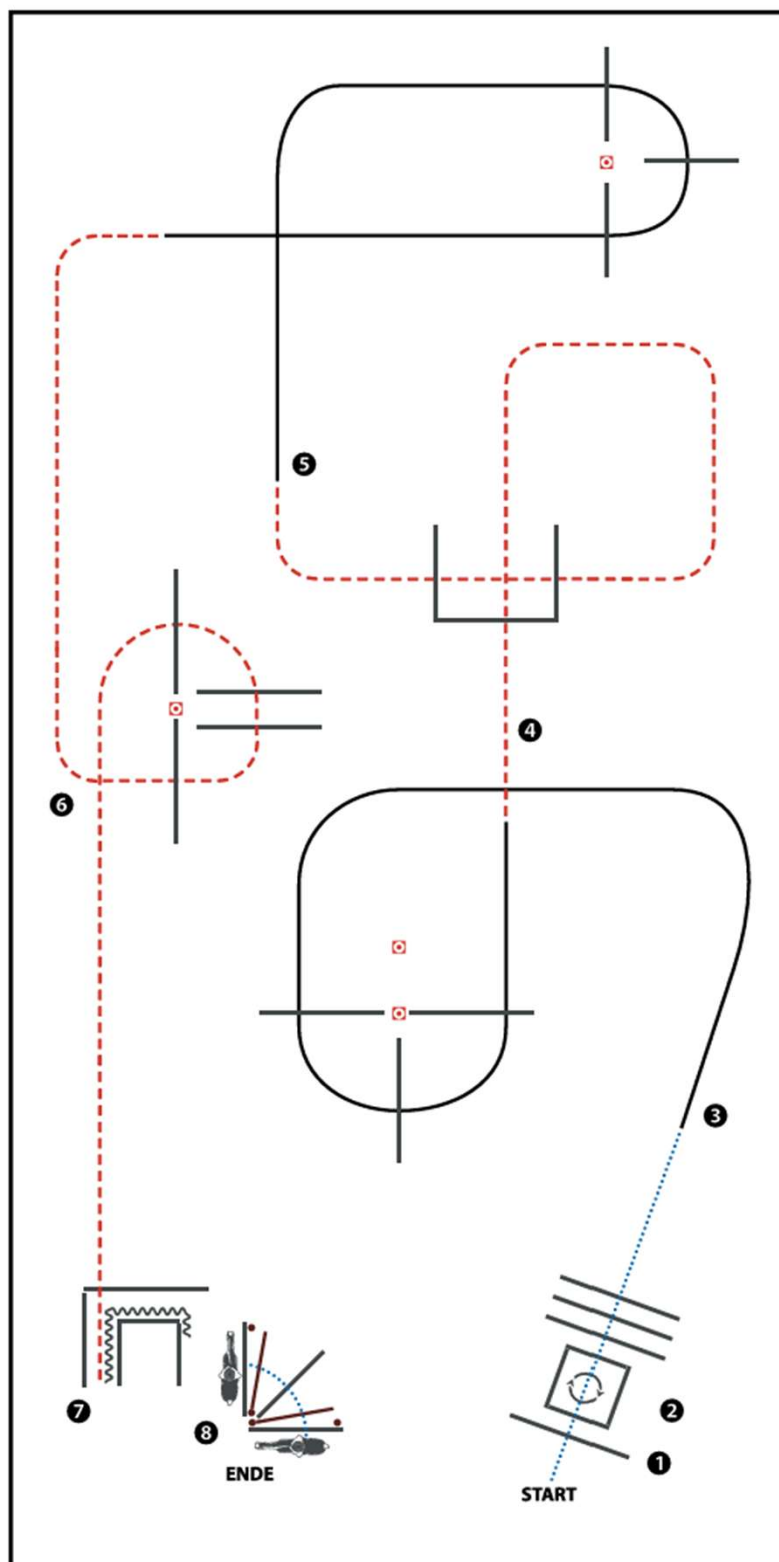

(Erhöhungen optional)

- 1) WALK OVER, INTO BOX,
TURN 360° EITHER WAY (LEFT OR RIGHT)
- 2) WALK OUT, WALK OVER
- 3) LOPE OVER (LL)
- 4) JOG OVER
- 5) LOPE OVER (RL)
- 6) JOG OVER
- 7) JOG IN, BACK UP
- 8) GATE RIGHT HAND

NORWEGIAN
QUARTER
HORSE
ASSOCIATION



Big Dream
ARENA

#156	AQHA	138200	Open sr
#157	APHA	TRL3	Open sr
#158	NSBA	530300	Open

Trail

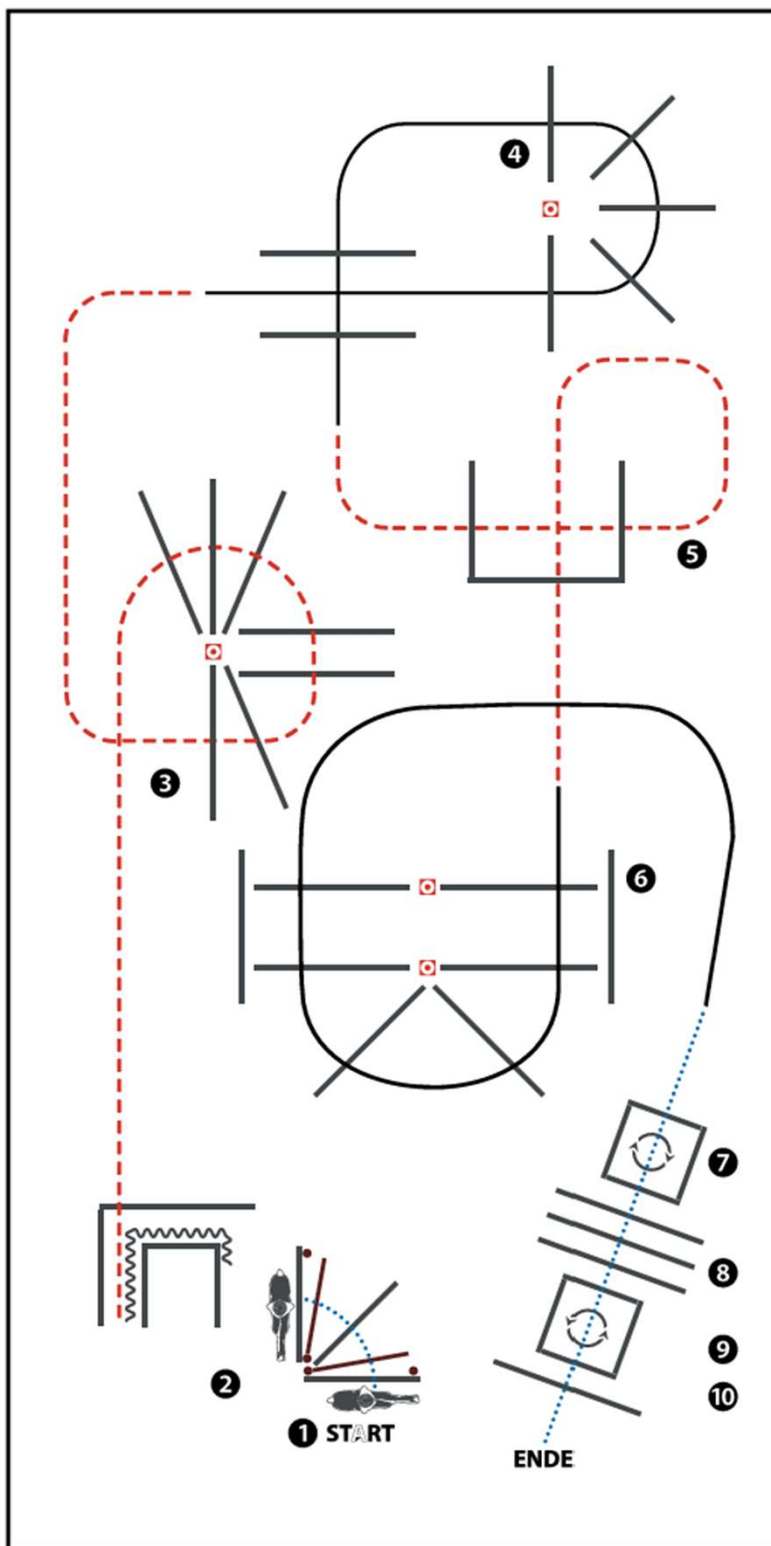

(Erhöhungen optional)

- 1) GATE LEFT HAND OPEN, WALK OVER, CLOSE GATE
- 2) BACK UP, JOG OUT
- 3) JOG OVER
- 4) LOPE OVER (LL)
- 5) JOG OVER
- 6) LOPE OVER (RL)
- 7) WALK INTO BOX, TURN 360° LEFT
- 8) WALK OVER
- 9) WALK INTO BOX, TURN 360° RIGHT
- 10) WALK OUT, WALK OVER

NORWEGIAN
QUARTER
HORSE
ASSOCIATION



Big Dream
ARENA

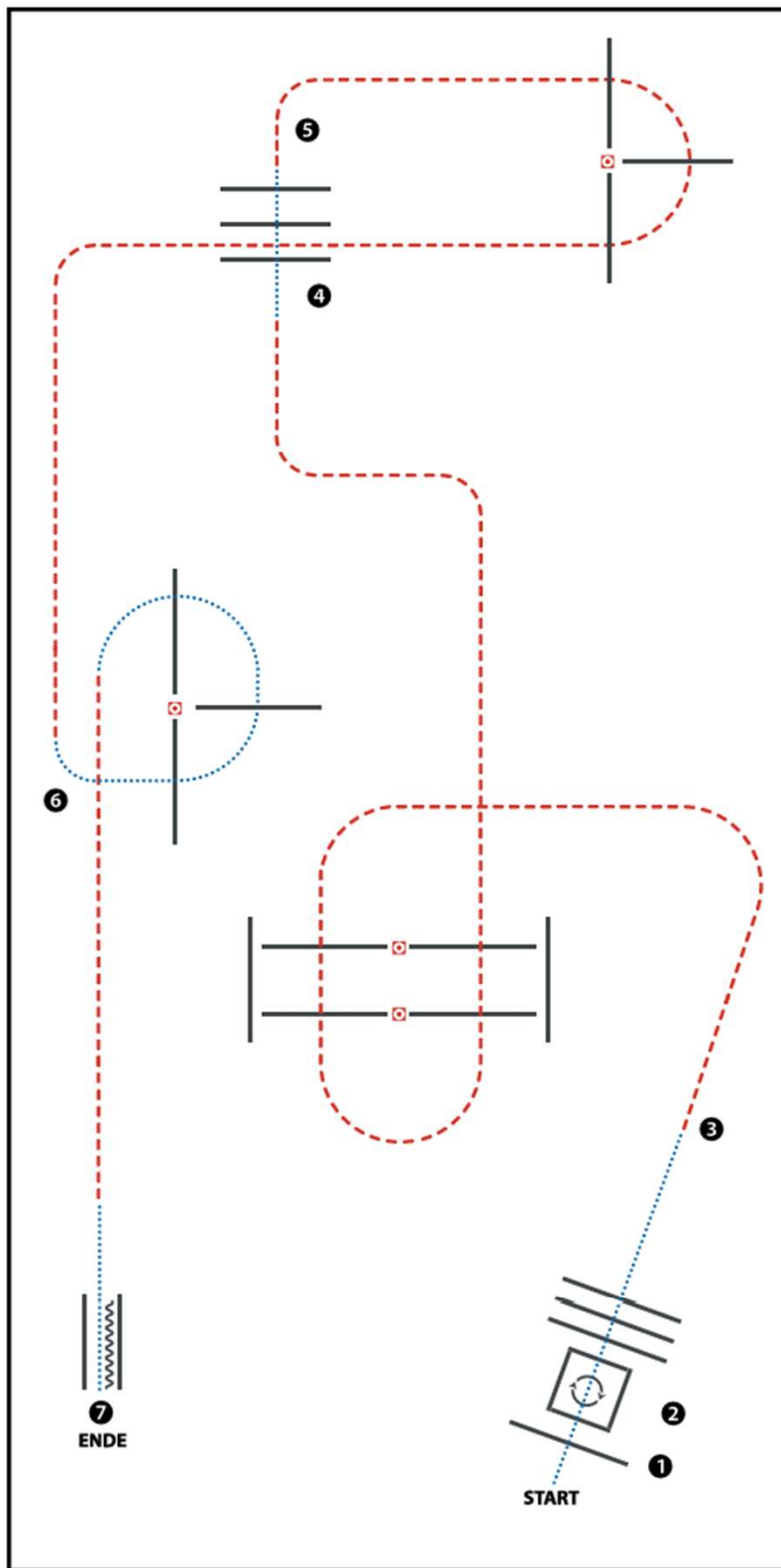

- 1) WALK INTO BOX, TURN 360° EITHER WAY
(im Schritt in die Box, Turn 360° rechts oder links)
- 2) WALK OUT, WALK OVER (Im Schritt aus der Box, Schrittstangen)
- 3) JOG OVER (Trabstangen)
- 4) WALK OVER (Schrittstangen)
- 5) JOG OVER (Trabstangen)
- 6) WALK OVER, JOG (Schrittstangen, Trab)
- 7) WALK IN, BACK UP (im Schritt in die Gasse, Rückwärts)



#161	AQHA	238300	Amateur	2&3 yrold	Trail in hand
#162	APHA	AIH2	Amateur	2 yrold	
#163	APHA	AIH4	Amateur	3 yrold & Older	

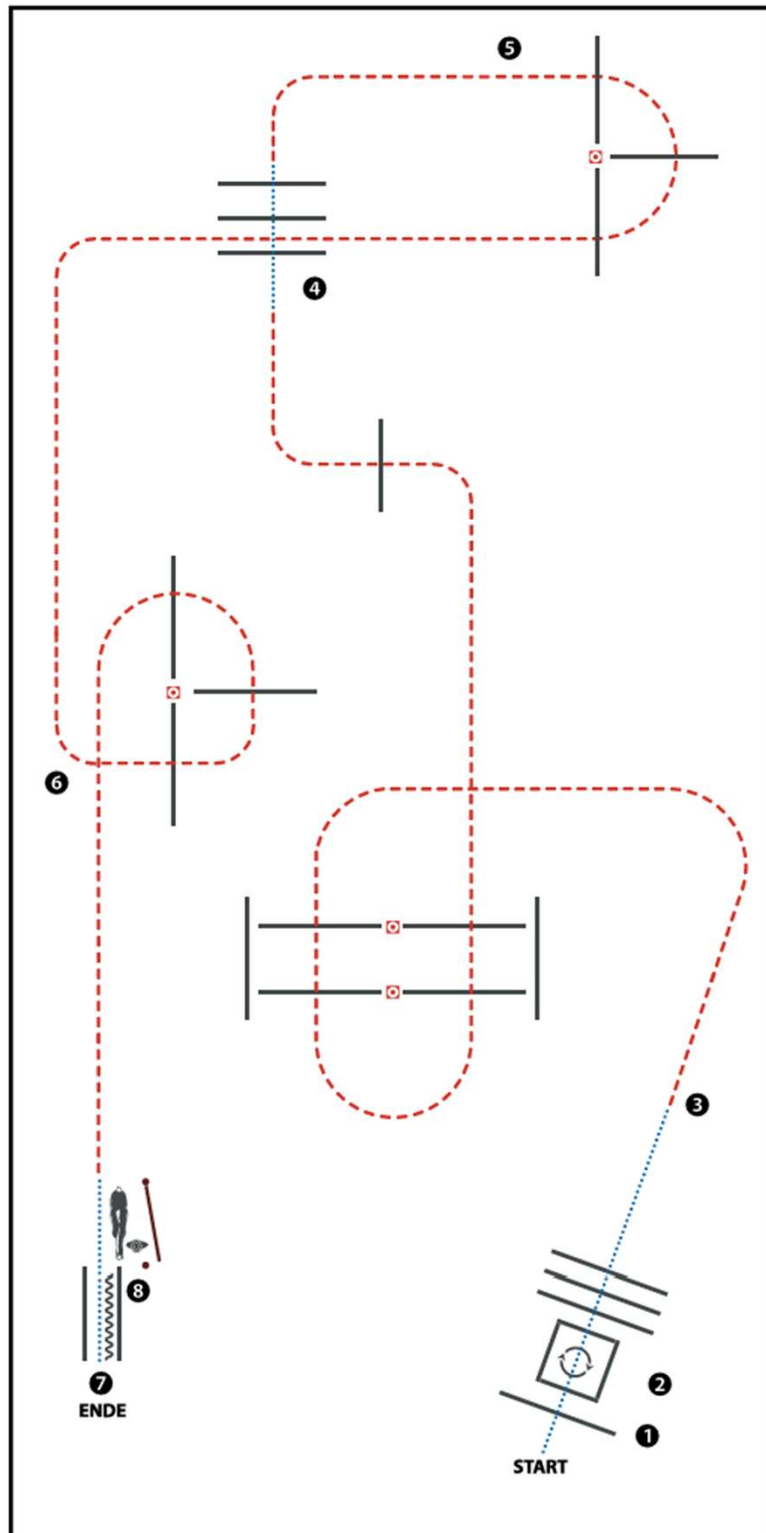

- 1) WALK OVER, INTO BOX,
TURN 360° EITHER WAY (LEFT OR RIGHT)
- 2) WALK OUT, WALK OVER
- 3) JOG OVER
- 4) WALK OVER
- 5) JOG OVER
- 6) JOG OVER
- 7) WALK IN, BACK UP
- 8) GATE (LEFT HAND)

NORWEGIAN
QUARTER
HORSE
ASSOCIATION



Big Dream
ARENA

#168

AQHA

440000

Youth

Western Horsemanship

#169

APHA

YH1

Youth

#170 240002 L1

#171 NH1

#172 140004 L1

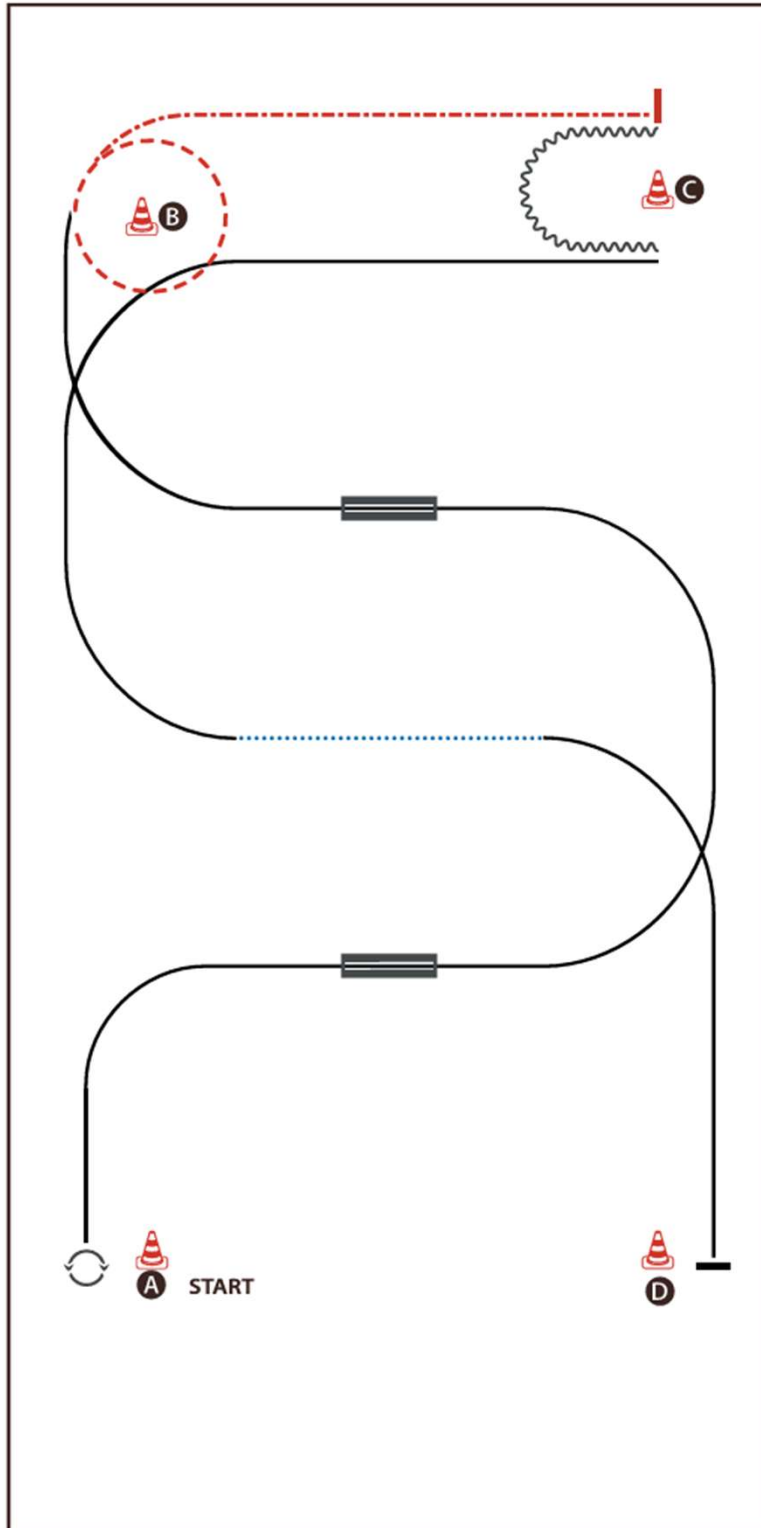

BE READY AT A

- 1) TURN 360° (LEFT OR RIGHT)
- 2) LOPE (RL), LEADCHANGE (SIMPLE OR FLYING)
- 3) LOPE (LL), LEADCHANGE (SIMPLE OR FLYING)
- 4) LOPE (RL)
- 5) JOG
- 6) EXTENDED JOG
- 7) STOP, BACK UP
- 8) LOPE (RL)
- 9) WALK
- 10) LOPE (LL), STOP

NORWEGIAN
QUARTER
HORSE
ASSOCIATION



Big Dream
ARENA

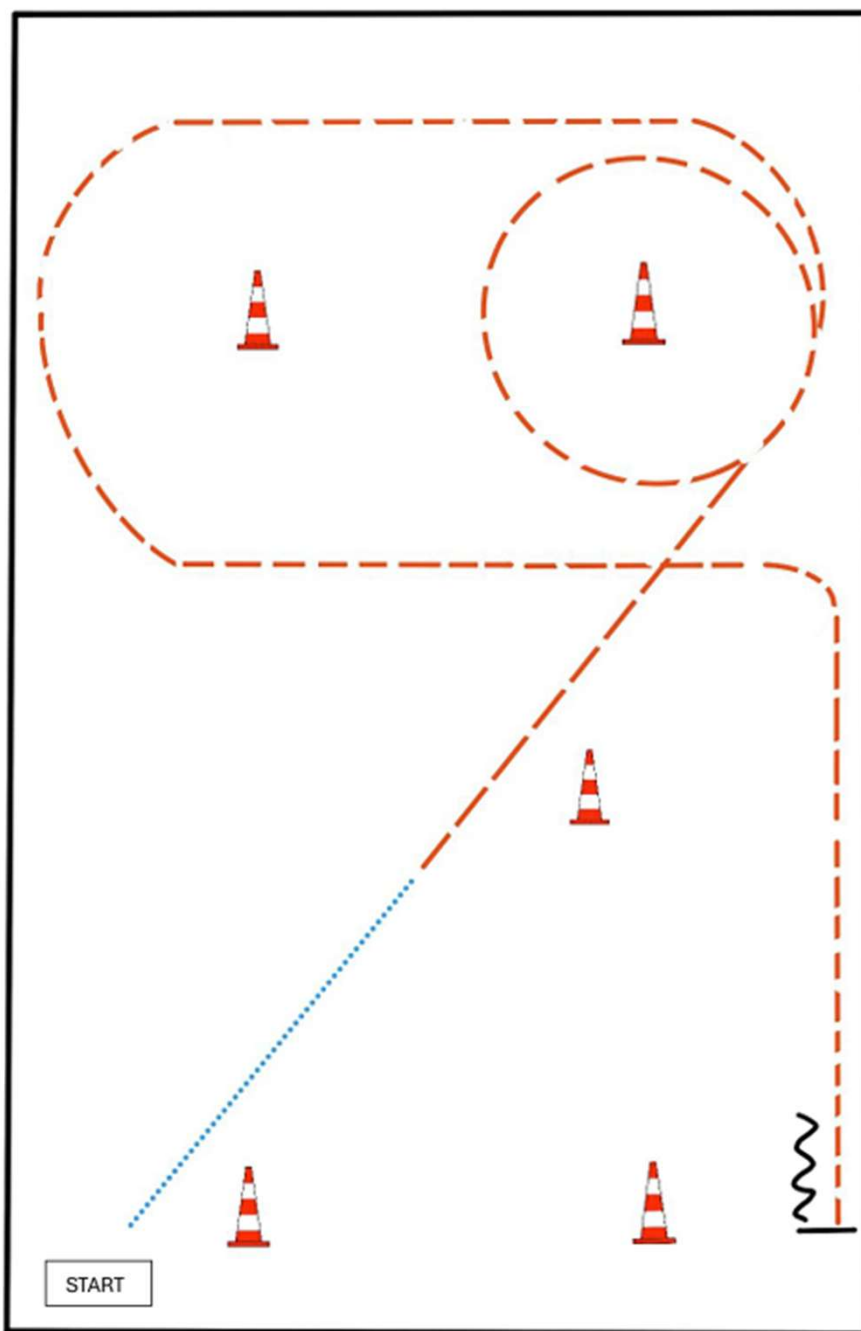

BE READY AT MARKER

1. WALK
2. JOG
3. JOG SMALL CIRCLE LEFT
4. JOG
5. STOP, BACK UP



#222
#223

Allbreed
NSBA

WHO 350601
Open Non Pro

Western Horsemanship

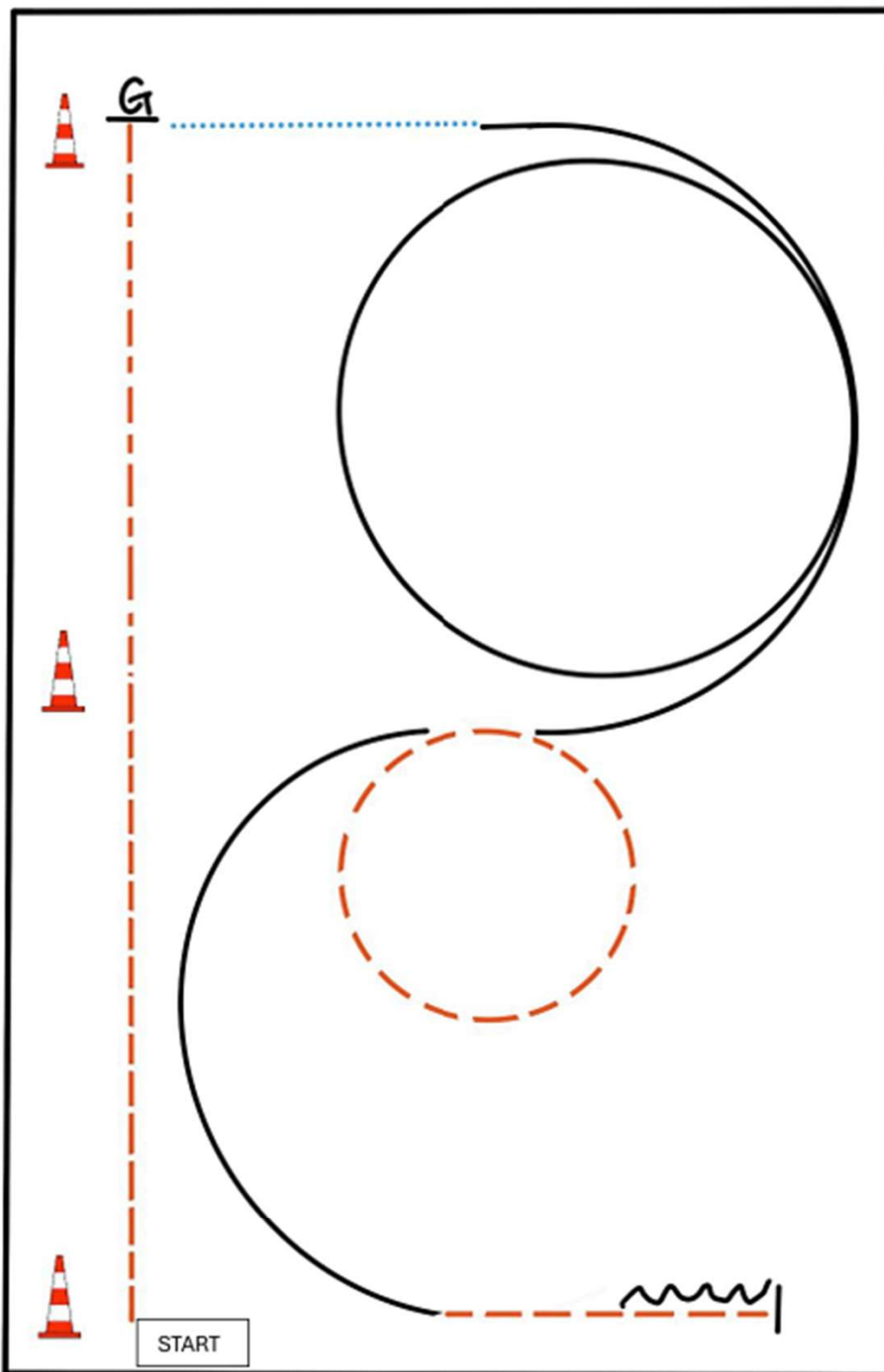

BE READY AT MARKER

- 1) JOG
- 2) EXTENDED JOG
- 3) STOP, TURN 270° LEFT
- 4) WALK
- 5) LOPE (RL)
- 6) JOG SMALL CIRCLE
- 7) LOPE (LL)
- 8) JOG
- 9) STOP, BACK UP

NORWEGIAN
QUARTER
HORSE
ASSOCIATION



Big Dream
ARENA

#231	AQHA	452000	Youth
#232	APHA	YEE1	Youth
#233	AQHA	252000	Amateur
#234	APHA	AHS1	Amateur

Hunt Seat Equitation

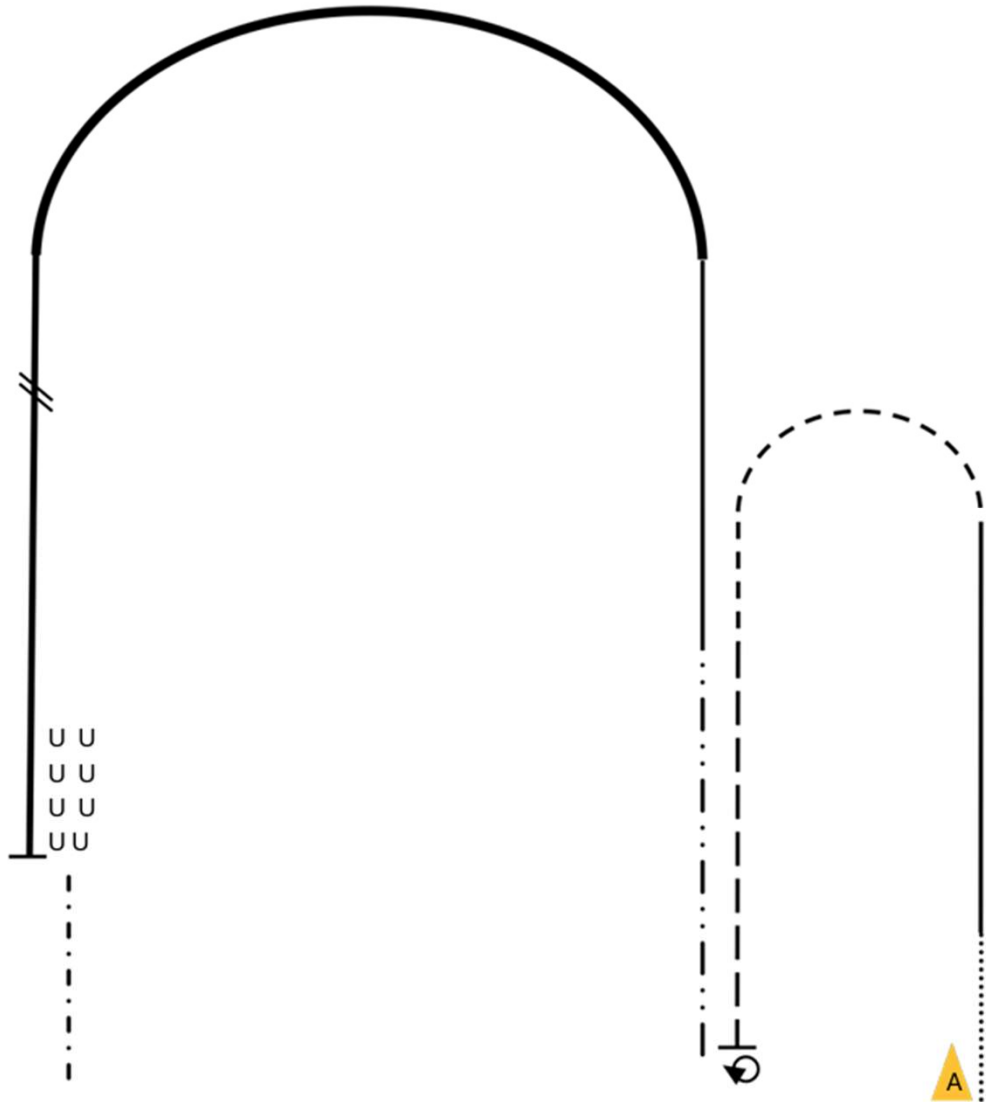

1. Walk from A , Canter right lead
2. Break to trot at right diagonal, around corner
3. Sitting trot, Stop
4. Perform a 180 ° turn to the left on the forehand
5. Trot, two point position
6. Canter left lead, build up to hand gallop, half a circle
7. Collect canter, change leads
8. Stop, back up one horse length
9. Trot left diagonal to exit

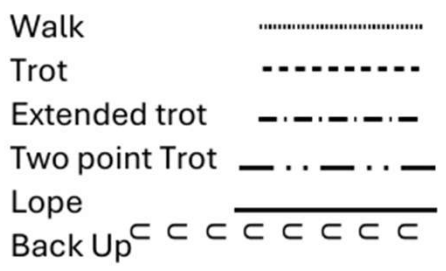

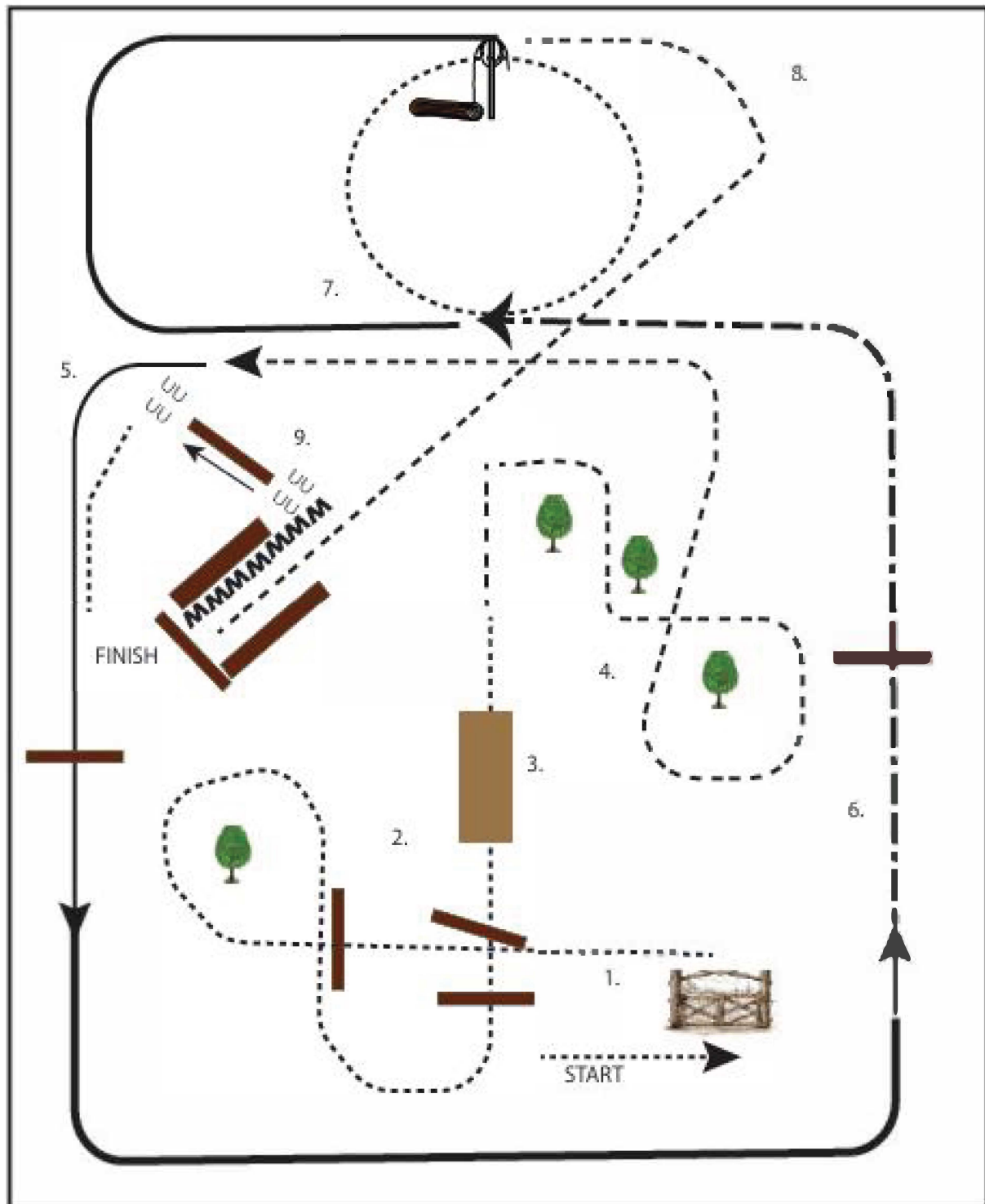

1. Work gate
2. Walk over logs
3. Walk over bridge
4. Trot around
5. Lope left lead and over log, extended lope, collected lope
6. Extended trot over log

7. Lope right lead, stop, drag log at walk or trot
 8. Trot into chute, stop, back through
 9. Sidepass to the right over log and walk forward
- Pattern completed

NORWEGIAN
QUARTER
HORSE
ASSOCIATION



Big Dream
ARENA

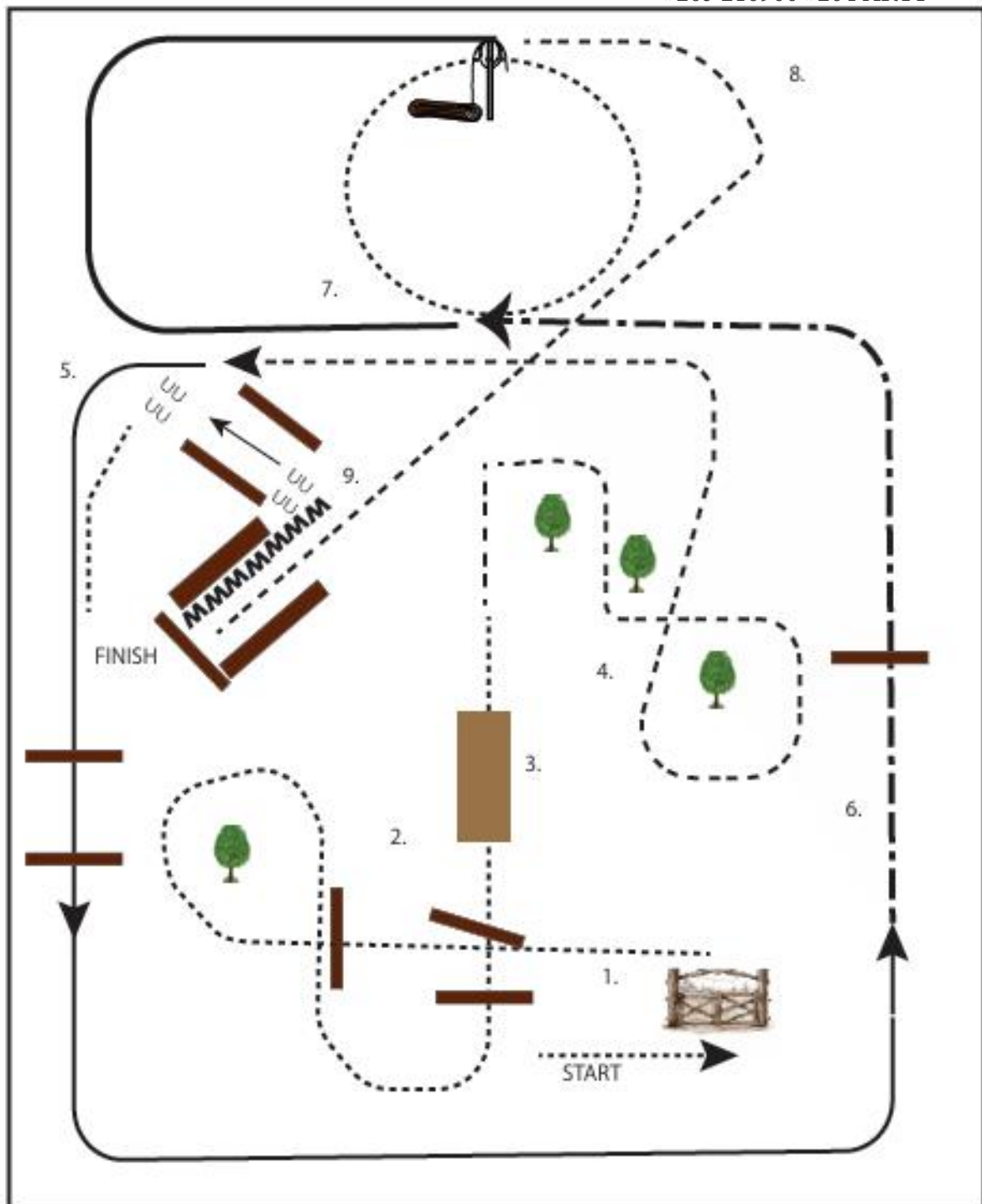

1. Work gate
2. Walk over logs
3. Walk over bridge
4. Trot around
5. Lope left lead and over logs,
6. Extended trot over log

7. Lope right lead, stop, drag log at walk or trot
 8. Trot into chute, stop, back through
 9. Sidepass to the right between logs and walk forward
- Pattern completed



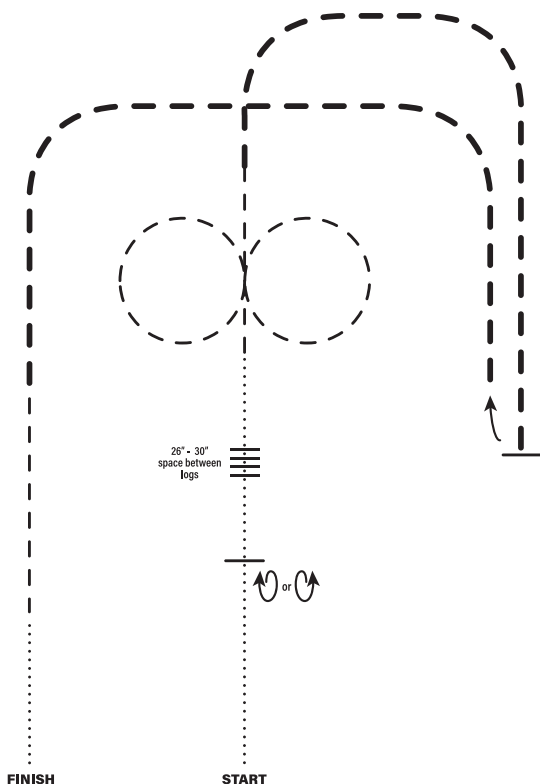

LEGEND

- Walk
- ... Extended Walk
- - - Trot
- - - Extended Trot
- Lope
- Extended Lope
- //// Back
- \\ Lead Change

1. Walk
2. Stop, 360° turn either direction
3. Walk over logs
4. Trot a figure 8, either direction first
5. Extended trot, stop
6. 180° (1/2) turn right
7. Extended trot
8. Collect to a trot
9. Walk

Note: The drawn description of this pattern is only intended for the general depiction of the pattern. Exhibitors should utilize the arena space to best exhibit their horses.

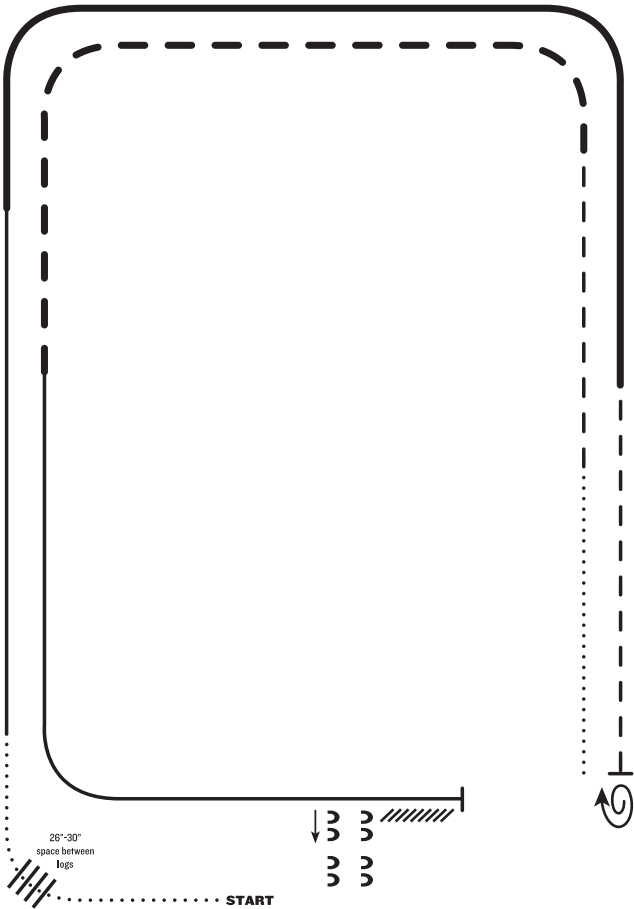
RANCH RIDING - PATTERN 6**LEGEND**

.....	Walk
....	Extended Walk
- - - -	Trot
- - - -	Extended Trot
————	Lope
————	Extended Lope
////	Back
∩	Lead Change

1. Walk
2. Walk over logs
3. Lope right lead
4. Extended lope right lead
5. Trot
6. Stop, 1 1/2 turn right
7. Walk
8. Trot
9. Extended trot
10. Lope left lead
11. Stop and back
12. Side pass right

Note: The drawn description of this pattern is only intended for the general depiction of the pattern. Exhibitors should utilize the arena space to best exhibit their horses.

RANCH RIDING - PATTERN 7

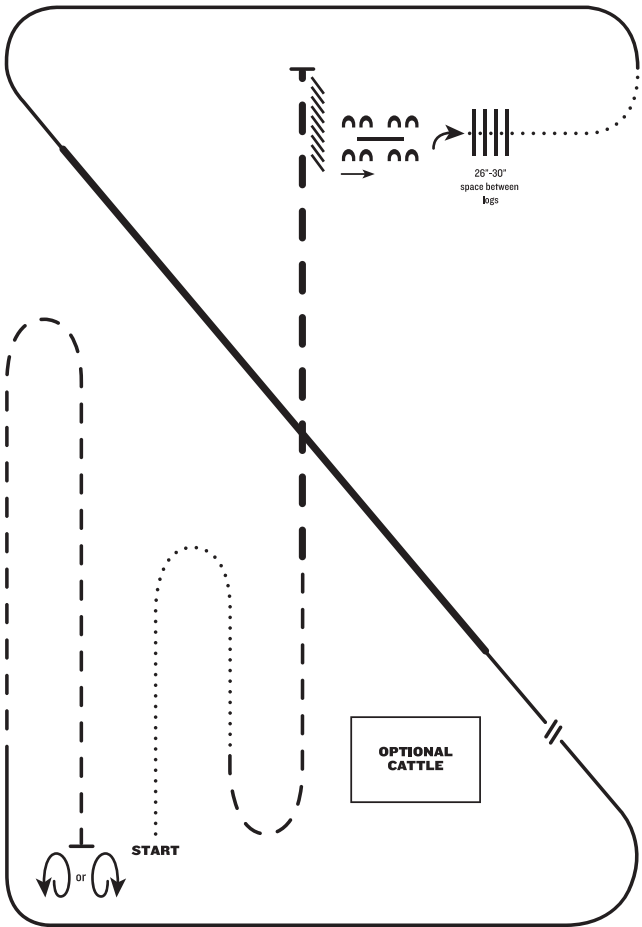

LEGEND

.....	Walk
...	Extended Walk
- - -	Trot
- - -	Extended Trot
—	Lope
—	Extended Lope
////	Back
∩	Lead Change

1. Walk
2. Trot
3. Extended trot
4. Stop and back
5. Side pass right over log
6. 1/4 turn right, walk over logs
7. Walk
8. Lope left lead
9. Extended lope left lead
10. Collect lope, change leads (simple or flying)
11. Lope right lead
12. Trot
13. Stop, one 360° turn either direction

Note: The drawn description of this pattern is only intended for the general depiction of the pattern. Exhibitors should utilize the arena space to best exhibit their horses.

RANCH RIDING - PATTERN 9

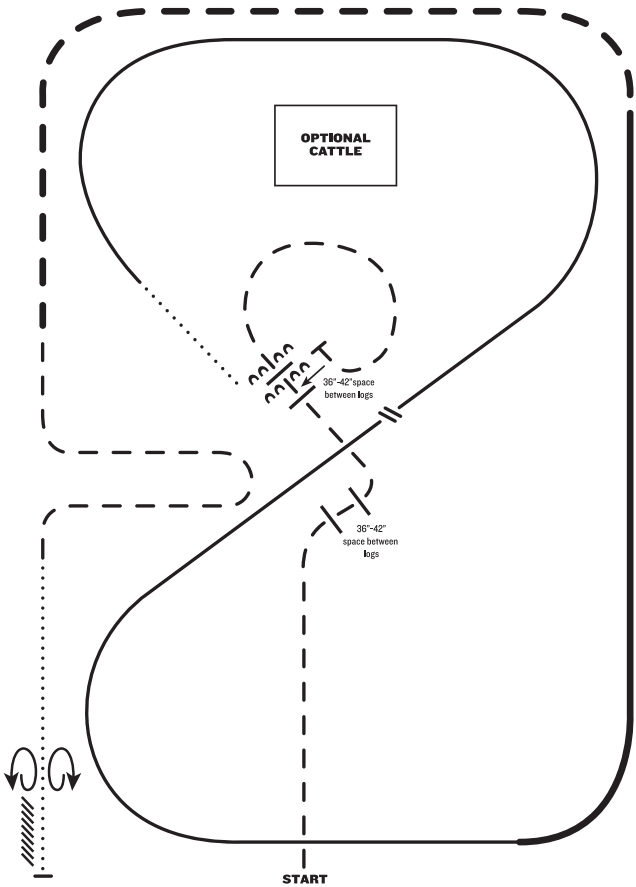

LEGEND

- Walk
- Extended Walk
- - - Trot
- - - Extended Trot
- Lope
- Extended Lope
- ////// Back
- \\ Lead Change

1. Trot
2. Trot over two sets of logs
3. Trot circle, stop and side pass left over log
4. Walk
5. Lope right lead
6. Change leads (simple or flying)
7. Lope left lead
8. Extended lope left lead
9. Extended trot
10. Trot
11. Walk
12. Stop and back
13. 360° turn each direction (either direction 1st) (L-R or R-L)

Note: The drawn description of this pattern is only intended for the general depiction of the pattern. Exhibitors should utilize the arena space to best exhibit their horses.

RANCH RIDING - PATTERN 10

#211 143000 #212 RHP1

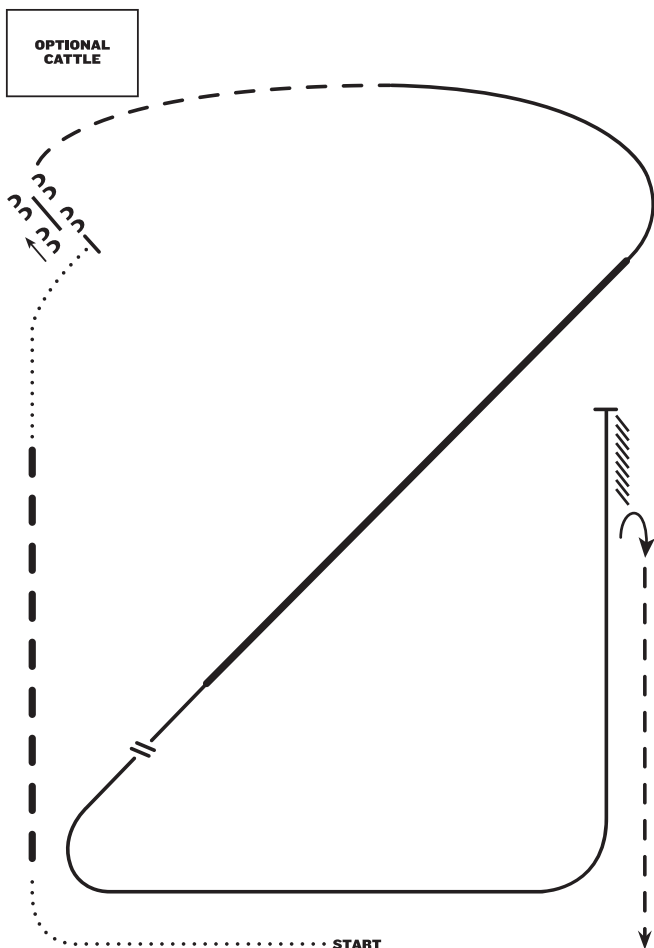

LEGEND	
.....	Walk
.....	Extended Walk
- - -	Trot
- - -	Extended Trot
—	Lope
—	Extended Lope
////	Back
∩	Lead Change

1. Walk
2. Extended trot
3. Walk
4. Stop, side pass left over log
5. Trot
6. Lope right lead
7. Extended lope right lead
8. Collect lope and change leads (simple or flying)
9. Lope left lead
10. Stop and back
11. 1/2 turn right
12. Trot

Note: The drawn description of this pattern is only intended for the general depiction of the pattern. Exhibitors should utilize the arena space to best exhibit their horses.

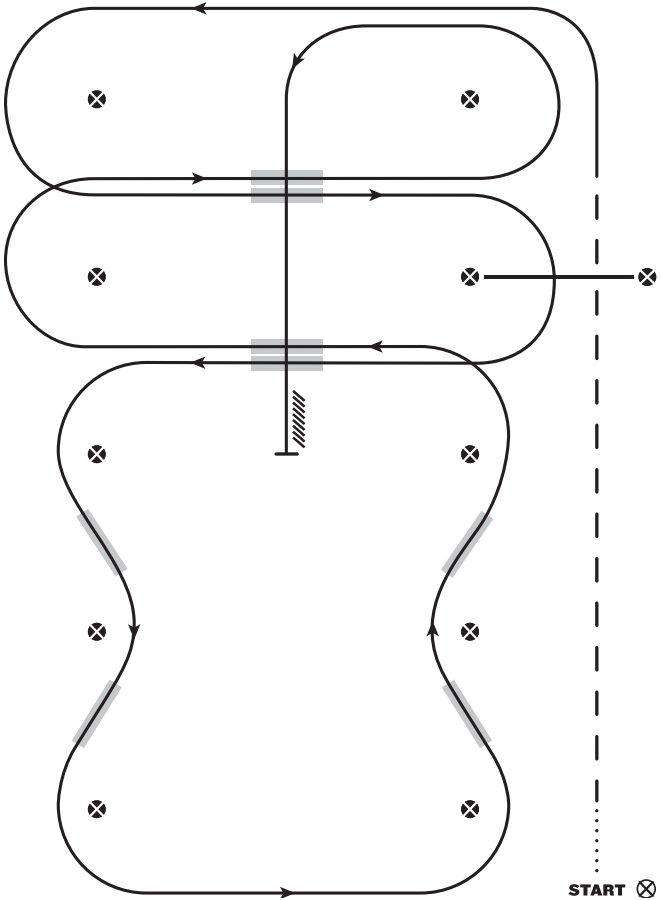
WESTERN RIDING PATTERN 3**LEGEND**

.....	Walk
- - - -	Jog
————	Lope
//////	Back
■	Lead Changing Area

1. Walk at least 15 feet from start cone to the first marker, transition to jog, jog over log.
2. Transition to the lope left lead
3. First crossing change
4. Lope over log
5. Second crossing change
6. First line change
7. Second line change
8. Third line change
9. Fourth line change
10. Third crossing change
11. Fourth crossing change
12. Lope up the center, stop & back

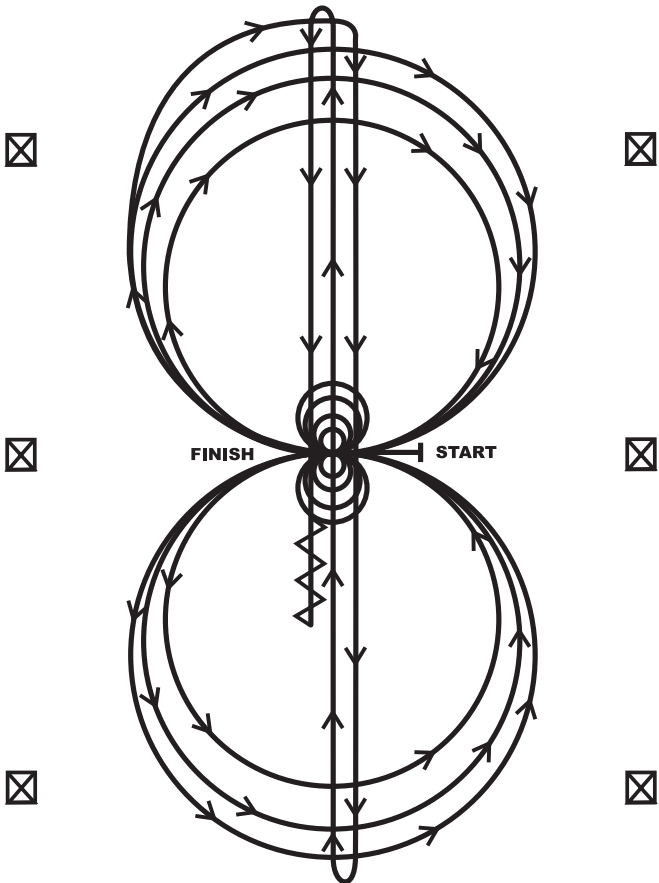
REINING PATTERN 2

Horses may walk or jog to the center of arena. Horses must walk or stop prior to starting pattern. Beginning at the center of the arena facing the left wall or fence.

1. Beginning on the right lead, complete three circles to the right: the first circle small and slow; the next two circles large and fast. Change leads at the center of the arena.
2. Complete three circles to the left: the first circle small and slow; the next two circles large and fast. Change leads at the center of the arena.
3. Continue around previous circle to the right. At the top of the circle, run down the middle to the far end of the arena past the end marker and do a right rollback—no hesitation.
4. Run up the middle to the opposite end of the arena past the end marker and do a left rollback—no hesitation.
5. Run past the center marker and do a sliding stop. Back up to the center of the arena or at least ten feet (three meters). Hesitate.
6. Complete four spins to the right. Hesitate.
7. Complete four spins to the left. Hesitate to demonstrate the completion of the pattern.

REINING PATTERN 4

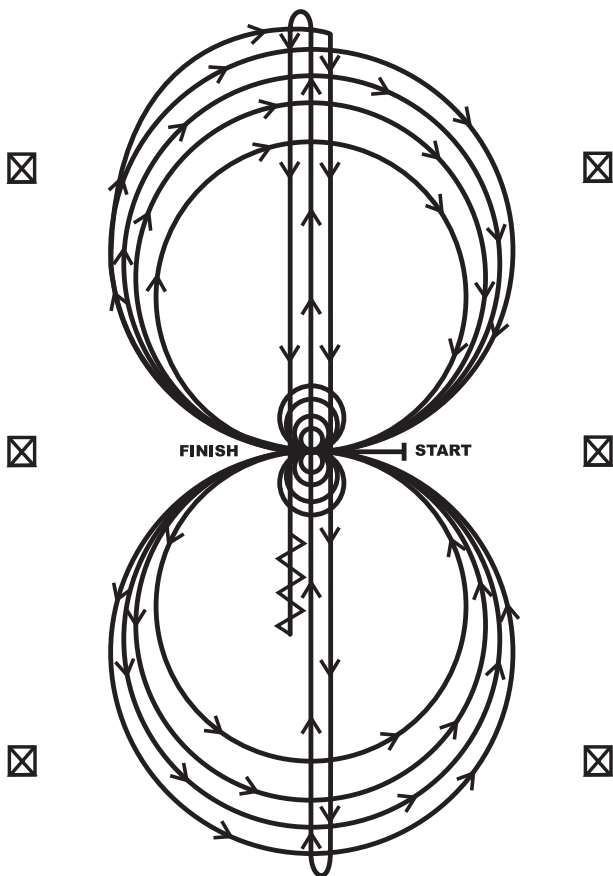

Horses may walk or jog to the center of the arena. Horses must walk or stop prior to starting pattern. Beginning at the center of the arena facing the left wall or fence.

1. Beginning on the right lead, complete three circles to the right: the first two large and fast; the third circle small and slow. Stop at the center of the arena. Hesitate.
2. Complete four spins to the right. Hesitate.
3. Beginning on the left lead, complete three circles to the left: the first two circles large and fast; the third circle small and slow. Stop at the center of the arena. Hesitate.
4. Complete four spins to the left. Hesitate.
5. Beginning on the right lead, run a large fast circle to the right, change leads at the center of the arena, run a large fast circle to the left, and change leads at the center of the arena. (Figure 8)
6. Continue around previous circle to the right. At the top of the circle, run down the middle to the far end of the arena past the end marker and do a right roll-back—no hesitation.
7. Run up the middle to the opposite end of the arena past the end marker and do a left roll-back—no hesitation.
8. Run past the center marker and do a sliding stop. Back up to the center of the arena or at least ten feet (three meters). Hesitate to demonstrate completion of the pattern.

REINING PATTERN 5

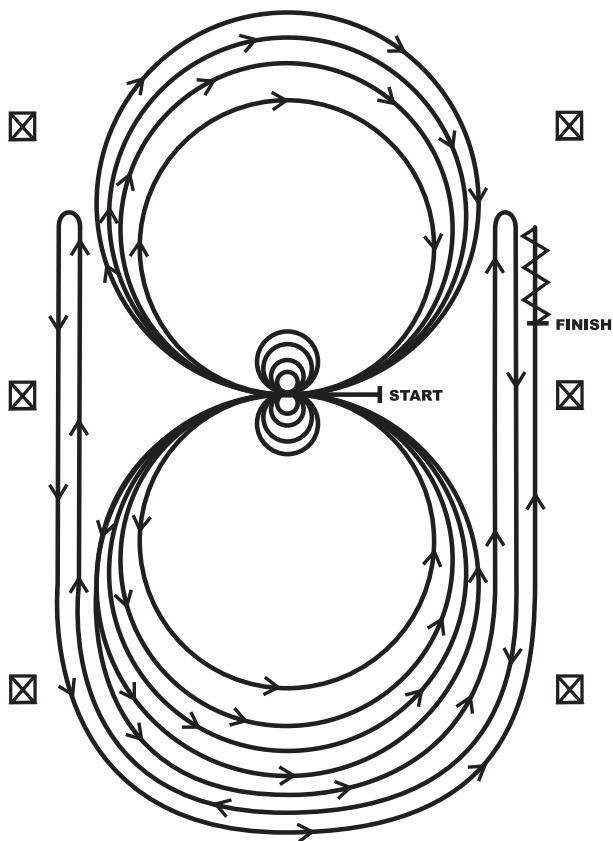

Horses may walk or jog to the center of arena. Horses must walk or stop prior to starting pattern. Beginning at the center of the arena facing the left wall or fence.

1. Beginning on the left lead, complete three circles to the left: the first two circles large and fast; the third circle small and slow. Stop at the center of the arena. Hesitate.
2. Complete four spins to the left. Hesitate.
3. Beginning on the right lead, complete three circles to the right: the first two circles large and fast; the third circle small and slow. Stop at the center of the arena. Hesitate.
4. Complete four spins to the right. Hesitate.
5. Beginning on the left lead, run a large fast circle to the left, change leads at the center of the arena, run a large fast circle to the right, and change leads at the center of the arena. (Figure 8)
6. Continue around previous circle to the left but do not close this circle. Run up the right side of the arena past the center marker and do a right rollback at least twenty feet (six meters) from the wall or fence—no hesitation.
7. Continue around previous circle but do not close this circle. Run up the left side of the arena past the center marker and do a left rollback at least twenty feet (six meters) from the wall or fence—no hesitation.
8. Continue back around previous circle but do not close this circle. Run up the right side of the arena past the center marker and do a sliding stop at least twenty feet (six meters) from the wall or fence. Back up at least ten feet (three meters). Hesitate to demonstrate completion of the pattern.

REINING PATTERN 6

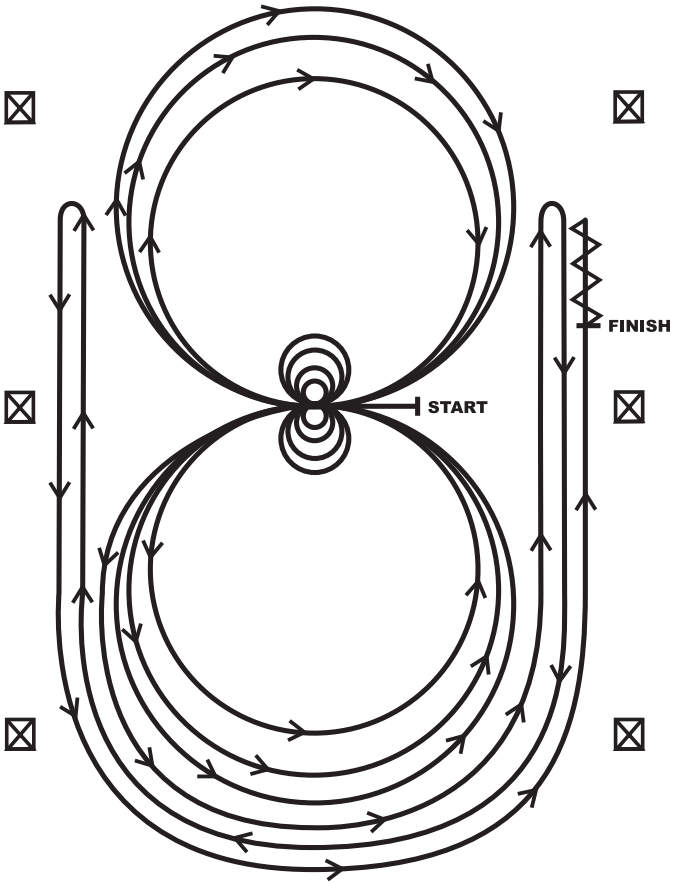

Horses may walk or jog to the center of arena. Horses must walk or stop prior to starting pattern. Beginning at the center of the arena facing the left wall or fence.

1. Complete four spins to the right. Hesitate.
2. Complete four spins to the left. Hesitate.
3. Beginning on the left lead, complete three circles to the left: the first two circles large and fast; the third circle small and slow. Change leads at the center of the arena.
4. Complete three circles to the right: the first two circles large and fast; the third circle small and slow. Change leads at the center of the arena.
5. Begin a large circle to the left but do not close this circle. Run up the right side of the arena past the center marker and do a right rollback at least twenty feet (six meters) from the wall or fence—no hesitation.
6. Continue back around previous circle but do not close this circle. Run up the left side of the arena past the center marker and do a left rollback at least twenty feet (six meters) from the wall or fence—no hesitation.
7. Continue back around previous circle but do not close this circle. Run up the right side of the arena past the center marker and do a sliding stop at least twenty feet (six meters) from the wall or fence. Back up at least ten feet (three meters). Hesitate to demonstrate the completion of the pattern.

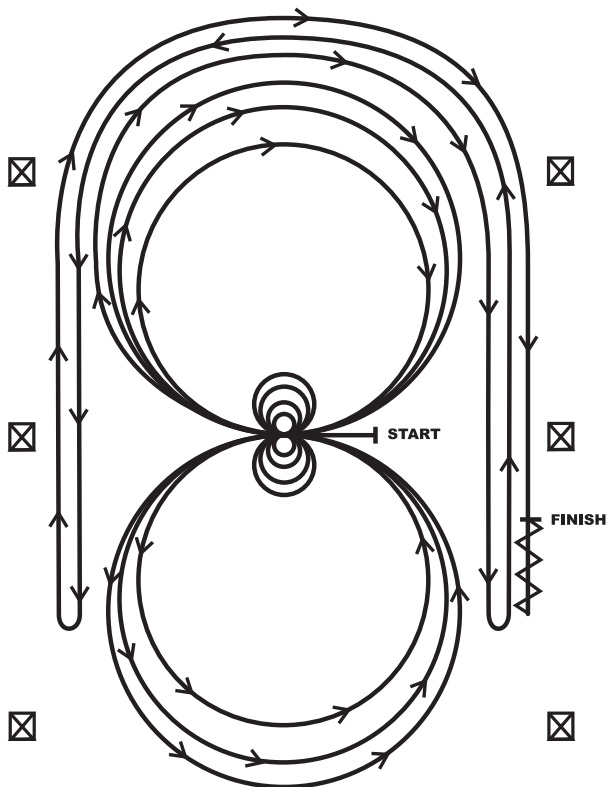
REINING PATTERN 8

Horses may walk or jog to the center of arena. Horses must walk or stop prior to starting pattern. Beginning at the center of arena facing the left wall or fence.

1. Complete four spins to the left. Hesitate.
2. Complete four spins to the right. Hesitate.
3. Beginning on the right lead, complete three circles to the right: the first circle large and fast; the second circle small and slow; the third circle large and fast. Change leads at the center of the arena.
4. Complete three circles to the left: the first circle large and fast; the second circle small and slow; the third circle large and fast. Change leads at the center of the arena.
5. Begin a large circle to the right but do not close this circle. Run straight down the right side of the arena past the center marker and do a left rollback at least twenty feet (six meters) from the wall or fence—no hesitation.
6. Continue back around the previous circle but do not close this circle. Run down the left side of the arena past the center marker and do a right rollback at least twenty feet (six meters) from the wall or fence—no hesitation.
7. Continue back around the previous circle but do not close this circle. Run down the right side of the arena past the center marker and do a sliding stop at least twenty feet (six meters) from the wall or fence. Back up at least ten feet (three meters). Hesitate to demonstrate completion of the pattern.

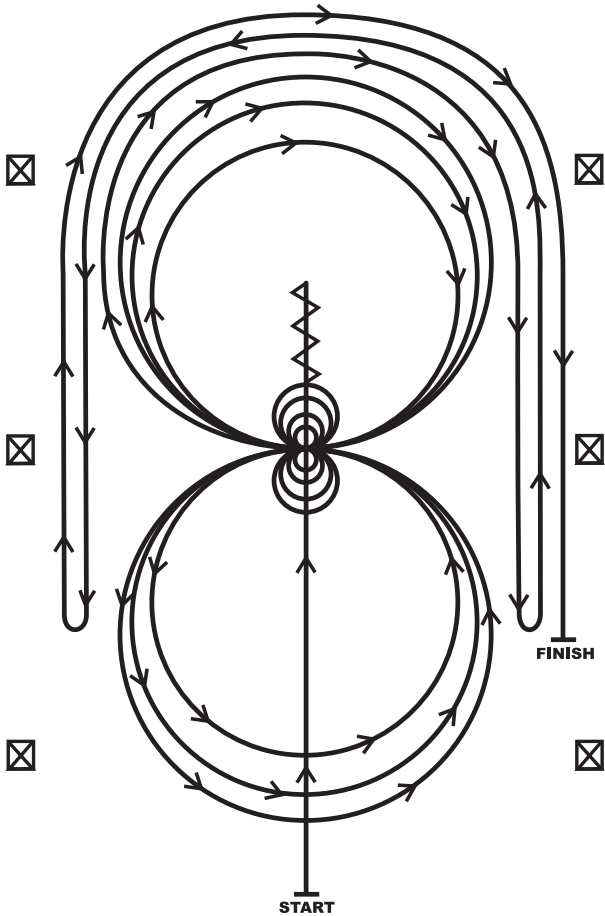
REINING PATTERN 10

1. Run past the center marker and do a sliding stop. Back up to the center of the arena or at least ten feet (three meters). Hesitate.
2. Complete four spins to the right. Hesitate.
3. Complete four and one-quarter spins to the left so that the horse is facing the left wall or fence. Hesitate.
4. Beginning on the right lead, complete three circles to the right: the first two circles large and fast, the third circle small and slow. Change leads at the center of the arena.
5. Complete three circles to the left: the first circle small and slow, the next two circles large and fast. Change leads at the center of the arena.
6. Begin a large circle to the right but do not close this circle. Run down the right side of the arena past the center marker and do a left rollback at least twenty feet (six meters) from the wall or fence—no hesitation.
7. Continue back around the previous circle but do not close this circle. Run down the left side of the arena past the center and do a right rollback at least twenty feet (six meters) from the wall or fence—no hesitation.
8. Continue back around previous circle but do not close this circle. Run down the right side of the arena past the center marker and do a sliding stop at least twenty feet (six meters) from the wall or fence. Hesitate to demonstrate completion of the pattern.

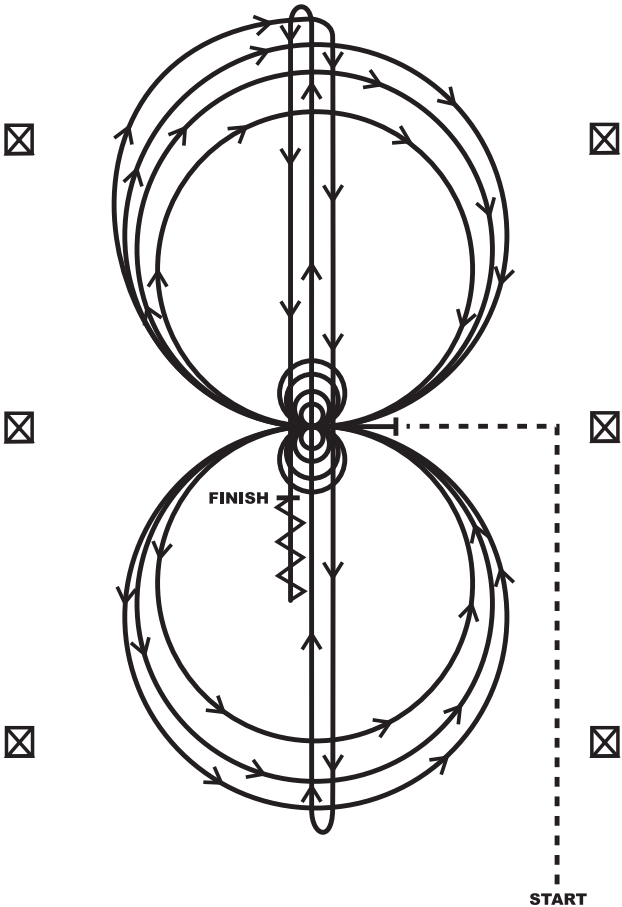
REINING PATTERN 11

Horses must jog the majority of the way (over $\frac{1}{2}$ the distance) to the center of the arena. Horses must walk or stop prior to starting the pattern. Beginning at the center of the arena facing the left wall or fence.

1. Complete four spins to the left. Hesitate.
2. Complete four spins to the right. Hesitate.
3. Beginning on the right lead complete three circles to the right; the first circle small and slow; the next two circles large and fast. Change leads at the center of the arena.
4. Complete three circles to the left; the first circle small and slow; the next two circles large and fast. Change leads at the center of the arena.
5. Begin a large circle to the right, but do not close this circle. Run down the center of the arena past the end marker and do a right rollback—no hesitation.
6. Run up the middle to the opposite end of the arena past the end marker and do a left rollback—no hesitation.
7. Run past the center marker and do a sliding stop. Back up to the center of the arena or at least ten feet (three meters). Hesitate to demonstrate completion of the pattern.

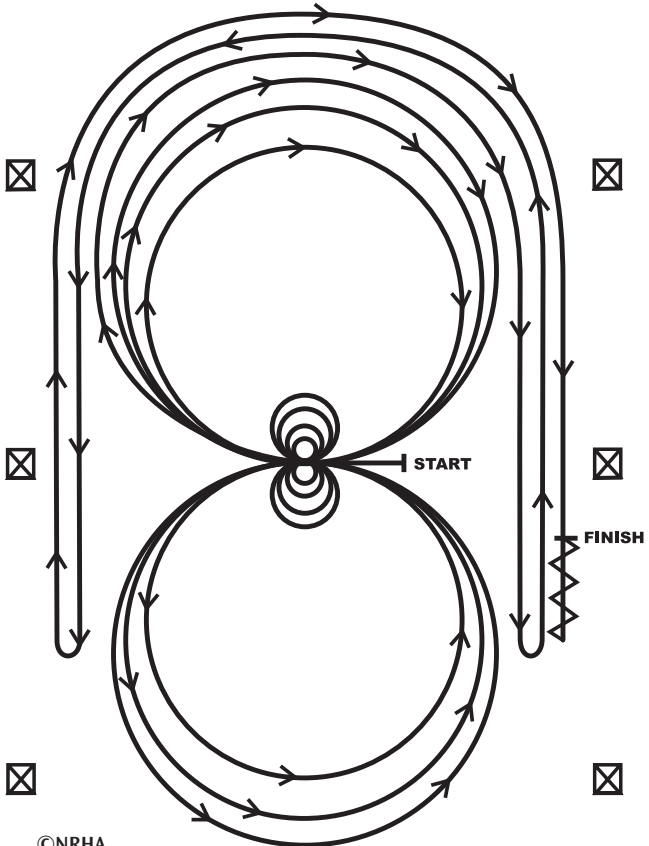
REINING PATTERN 14

©NRHA

Horses may walk or jog to the center of arena. Horses must walk or stop prior to starting pattern. Beginning at the center of the arena facing the left wall or fence.

1. Complete four spins to the left. Hesitate.
2. Complete four spins to the right. Hesitate.
3. Beginning on the right lead, complete three circles to the right: the first two circles large and fast; the third circle small and slow. Change leads at the center of the arena.
4. Complete three circles to the left: the first two circles large and fast; the third circle small and slow. Change leads at the center of the arena.
5. Begin a large circle to the right but do not close this circle. Run up the right side of the arena past the center marker and do a left rollback at least twenty feet (six meters) from the wall or fence—no hesitation.
6. Continue back around previous circle but do not close this circle. Run up the left side of the arena past the center marker and do a right rollback at least twenty feet (six meters) from the wall or fence—no hesitation.
7. Continue back around previous circle but do not close this circle. Run up the right side of the arena past the center marker and do a sliding stop at least twenty feet (six meters) from the wall or fence. Back up at least ten feet (three meters). Hesitate to demonstrate the completion of the pattern.

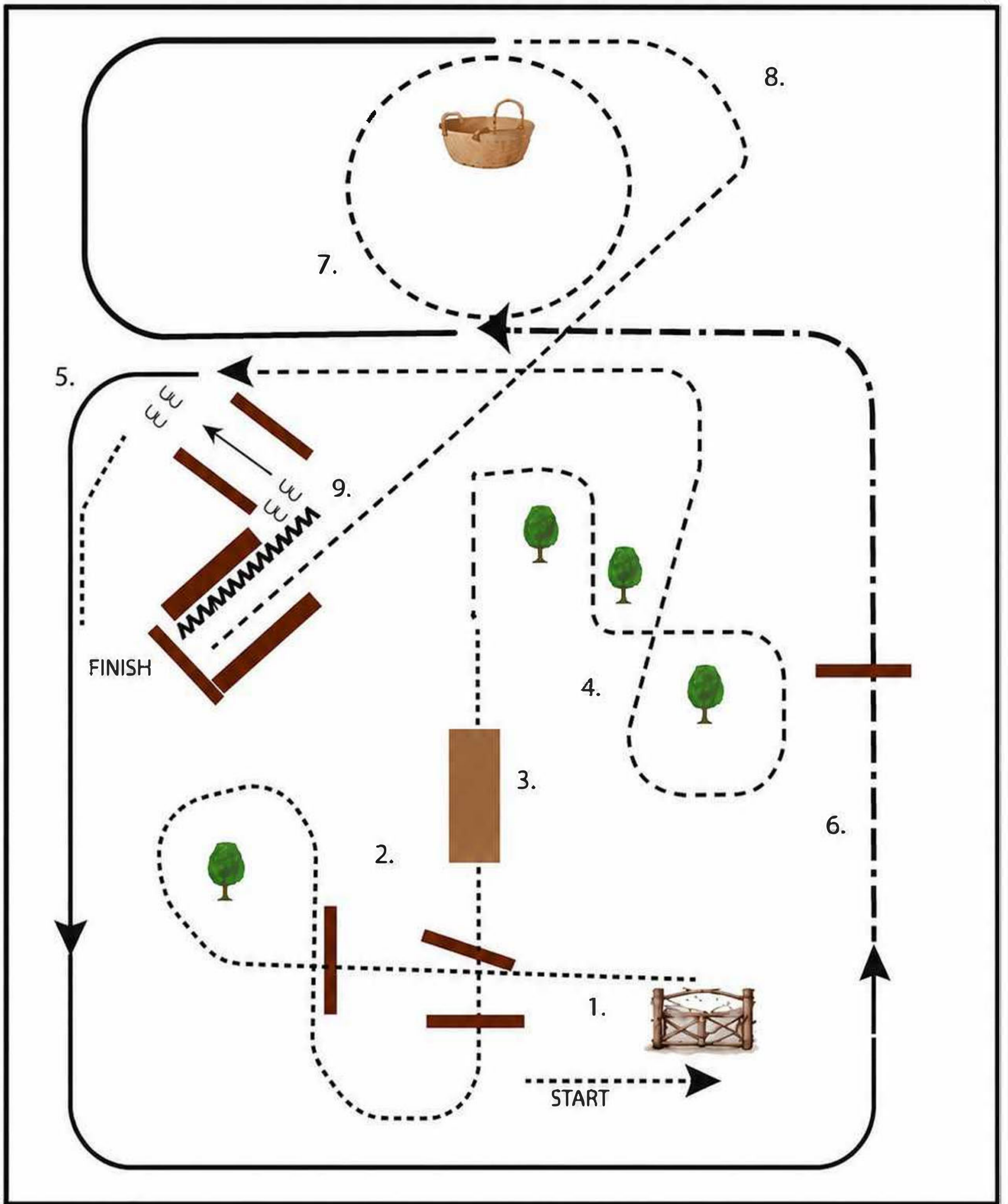

- 1. Work gate
- 2. Walk over logs
- 3. Walk over bridge
- 4. Trot around
- 5. Trot in two point position
- 6. Extended trot over log

- 7. Trot two point position, stop, pick up basket, trot a circle, stop and replace it
 - 8. Trot into chute, stop, back through
 - 9. Sidpass to the right between logs and walk forward
- Pattern completed